

OMNIS Dosing Module

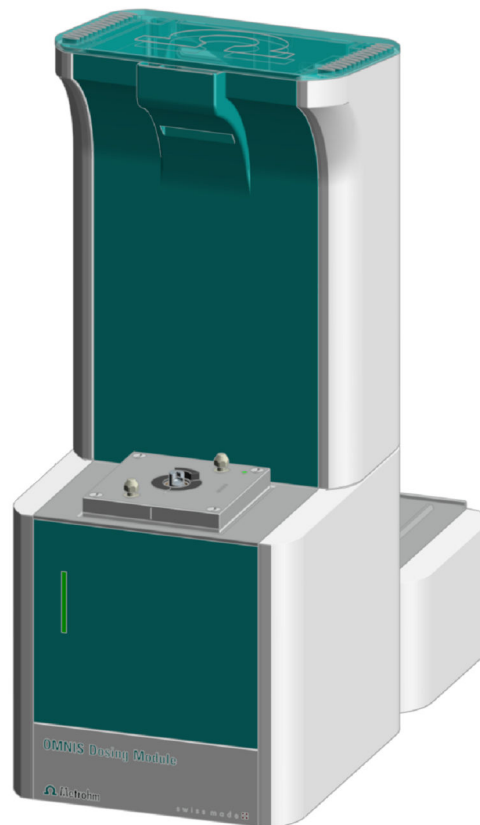

2.1003.0X10

Product manual

8.1003.8002EN / 2021-07-23



Metrohm AG
Ionenstrasse
CH-9100 Herisau
Switzerland
+41 71 353 85 85
info@metrohm.com
www.metrohm.com

OMNIS Dosing Module

2.1003.0X10

Product manual

8.1003.8002EN /
2021-07-23

Technical Communication
Metrohm AG
CH-9100 Herisau

This documentation is protected by copyright. All rights reserved.

This documentation has been prepared with great care. However, errors can never be entirely ruled out. Please send comments regarding possible errors to the address above.

Disclaimer

Deficiencies arising from circumstances that are not the responsibility of Metrohm, such as improper storage or improper use, etc., are expressly excluded from the warranty. Unauthorized modifications to the product (e.g. conversions or attachments) exclude any liability on the part of the manufacturer for resulting damage and its consequences. Instructions and notes in the Metrohm product documentation must be strictly followed. Otherwise, Metrohm's liability is excluded.

Table of contents

1	Overview	1
1.1	OMNIS Dosing Module – Product description	1
1.2	OMNIS Dosing Module – Product versions	1
1.3	Symbols and conventions	2
1.4	Further information	2
1.5	Accessories	2
2	Safety	4
2.1	Intended use	4
2.2	Responsibility of the operator	4
2.3	Requirements for operating personnel	5
2.4	Safety instructions	5
2.4.1	Danger from electrical potential	5
2.4.2	Danger from biological and chemical hazardous substances	5
2.4.3	Danger from highly flammable substances	6
2.4.4	Danger from leaking liquids	6
2.4.5	Danger during transport of the product	7
2.5	Design of warning messages	7
2.6	Meaning of warning signs	8
3	Functional description	9
3.1	OMNIS Dosing Module – Overview	9
3.1.1	Magnetic stirrer – Overview	11
3.1.2	Magnetic stirrer with accessories – Overview	12
3.1.3	Dosing unit – Overview	13
3.1.4	Bottle unit – Overview	17
3.1.5	Volumetric Karl Fischer titration cell – Overview	20
3.2	OMNIS Dosing Module – Function	21
3.2.1	Magnetic stirrer – Functional description	21
3.2.2	Dosing unit – Function	21
3.2.3	Bottle unit – Function	22
3.2.4	Volumetric Karl Fischer titration cell – Function	23
3.3	OMNIS Dosing Module - Indicators	24
3.4	System – Signals	24
3.5	OMNIS Dosing Module - Interfaces	25
4	Delivery and packaging	26
4.1	Delivery	26



11.4	OMNIS Dosing Module – Dimensions	67
11.5	Magnetic stirrer – Dimensions	68
11.6	OMNIS Dosing Module – Housing	68
11.7	Magnetic stirrer – Housing	68
11.8	OMNIS Dosing Module – Connectors specifications	69
11.9	Display specifications	69
11.10	OMNIS Dosing Module – Liquid Handling specifications	69
11.11	Magnetic stirrer – Specifications	69

1 Overview

1.1 OMNIS Dosing Module – Product description

The OMNIS Dosing Module is a dosing module that is controlled by an OMNIS Titrator. The OMNIS Dosing Module is equipped with the following functional units:

- One dosing unit with interchangeable cylinder units.
- One integrated magnetic stirrer, depending on the product version.

1.2 OMNIS Dosing Module – Product versions

The product is available in the following versions:

Table 1 Product versions

Article number	Designation	Version feature
2.1003.0010	OMNIS Dosing Module	without magnetic stirrer
2.1003.0110	OMNIS Dosing Module	with magnetic stirrer

The article number and serial number for identifying the product can be found on the type plate:

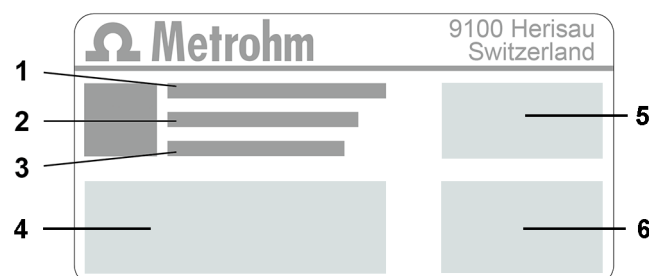

1	(01) = Article number in accordance with GS1 standard	2	(21) = Serial number
3	(240) = Metrohm article number	4	Certification
5	Certification	6	Technical specifications



1.3 Symbols and conventions

The following formatting may appear in the documentation:

(5- 12)	Cross-reference to figure legend The first number refers to the figure number. The second number refers to the product part in the figure.
1	Instruction step Numbers indicate the order of the instructions steps.
Method	Names of parameters, menu items, tabs and dialog windows
File ▶ New	Menu path
[Continue]	Button or key

1.4 Further information

The Metrohm Knowledge Base <https://guide.metrohm.com> always provides the current version of this document. Further instructions, leaflets, release notes etc. may be available, depending on the product. You can directly access the required information or the associated PDF document using the full-text search function and filters.

1.5 Accessories

Up-to-date information on the scope of delivery and on optional accessories can be found on the Metrohm website. Download this information as follows:

Downloading the accessories list

- 1** Go to <https://www.metrohm.com>.
- 2** Enter the article number of the product (e.g. **2.1001.0010**) into the search field.

The search result is displayed.
- 3** Click on the product.

Detailed information regarding the product is shown on various tabs.

4 On the **Included parts** tab, click the link to download the PDF.
The PDF file with the accessories data is loaded.

 Metrohm recommends downloading the accessories list from the Internet and keeping it for reference purposes.

2.3 Requirements for operating personnel

Only qualified personnel may operate the product. Qualified personnel are persons who meet the following requirements:

- Basic regulations on occupational safety and accident prevention for chemical laboratories are known and complied with.
- Knowledge of handling hazardous chemicals is present. Personnel have the ability to recognize and avoid potential dangers.
- Knowledge regarding the application of fire prevention measures for laboratories is available.
- Safety-relevant information is communicated and understood. The personnel can operate the product safely.
- The user documentation has been read and understood. The personnel operate the product according to the instructions in the user documentation.

2.4 Safety instructions

2.4.1 Danger from electrical potential

Contact with electrical potential can cause serious injuries or death. To avoid danger from electrical potential, observe the following:

- Operate the product only if it is in perfect condition. The housing must also be intact.
- Only use the product with the covers fitted. If covers are damaged or missing, disconnect the product from the energy supply and contact the regional Metrohm service representative.
- Protect live components (e.g. power supply unit, power cord, connection sockets) against moisture.
- Always have maintenance work and repairs on electrical components carried out by a regional Metrohm service representative.
- Disconnect the product from the energy supply immediately if at least one of the following cases occurs:
 - The housing is damaged or open.
 - Live parts are damaged.
 - Moisture penetrates.

2.4.2 Danger from biological and chemical hazardous substances

Contact with biological hazardous substances may cause poisoning from toxins or infections from microorganisms. Contact with aggressive chemical substances may cause poisoning or chemical burns. To avoid danger from biological or chemical hazardous substances, observe the following:



- Label the product according to regulations if it is used for substances that have a potential for chemical hazards and are generally subject to the Hazardous Substances Ordinance.
- Wear personal protective equipment (e.g. protective glasses, gloves).
- Use exhaust equipment when working with vaporizing hazardous substances.
- Dispose of hazardous substances in accordance with regulations.
- Clean and disinfect contaminated surfaces.
- Only use detergents that do not cause any unwanted side reactions with the materials to be cleaned.
- Dispose of chemically contaminated materials (e.g. cleaning material) in accordance with regulations.
- Proceed as follows in case of a return shipment to Metrohm AG or a regional Metrohm representative:
 - Decontaminate the product or product component.
 - Remove the labeling for hazardous substances.
 - Create a declaration of decontamination and enclose it with the product.

2.4.3 Danger from highly flammable substances

Using highly flammable substances or gases may cause fires or explosions. To avoid danger from highly flammable substances, observe the following:

- Avoid ignition sources.
- Use protective grounding.
- Use exhaust equipment.

2.4.4 Danger from leaking liquids

Leaking liquids may cause injuries and may damage the product. To avoid danger from leaking liquids, observe the following:

- Check the product and its accessories for leakages and loose connections.
- Replace leaking parts and connecting elements without delay.
- Tighten loose connecting elements.
- Do not loosen tubing connections under pressure.
- Do not remove aspiration tubing under pressure.
- Carefully pull the ends of the tubing out of the containers.
- Carefully let liquids from tubing drain into suitable containers.
- Insert the buret tips completely into the containers.
- Remove and dispose of leaked liquids in accordance with regulations.
- If you suspect that liquid has penetrated the instrument, disconnect the instrument from the energy supply. Then have the instrument checked by a regional Metrohm service representative.

2.4.5 Danger during transport of the product

Chemical or biological substances may be spilled during the transport of the product. Parts of the product may fall down or may be damaged. There is a risk of injury from chemical or biological substances and pieces of broken glass. To ensure safe transport, observe the following:

- Remove loose parts (e.g. sample racks, sample vessels, bottles) before transport.
- Remove liquids.
- Lift and transport the product with both hands on the base plate.
- Lift and transport heavy products only according to instructions.

2.5 Design of warning messages

There are 4 hazard levels for warning messages. The following signal words are used for classifying the hazard levels in warning messages:

- **DANGER** indicates a hazardous situation which, if not avoided, will result in serious injury or death.
- **WARNING** indicates a hazardous situation which, if not avoided, could result in serious injury or death.
- **CAUTION** indicates a hazardous situation which, if not avoided, could result in minor or moderate injury.
- **NOTICE** indicates a hazardous situation which, if not avoided, could result in property damage.

Warning messages differ in design (color and warning sign) depending on the hazard level:

DANGER

Type and source of danger

Consequences when not observing the notice: An irreversible injury that may result in death is very probable.

- Measures to avoid the danger

WARNING

Type or source of danger

Consequences when not observing the notice: A serious injury that may result in death is probable.

- Measures to avoid the danger

CAUTION

Type or source of danger

Consequences when not observing the notice: A minor to moderate injury is probable.











- Measures to avoid the danger



2.6 Meaning of warning signs

This documentation uses the following warning signs:

Table 2 Warning sign according to ISO 7010

Warning sign	Meaning
	General warning sign
	Warning of electrical voltage
	Warning of hand injuries
	Warning of sharp object
	Warning of hot surface
	Warning of biological hazard
	Warning of toxic materials
	Warning of flammable materials
	Warning of corrosive substances
	Warning of optical radiation
	Warning of laser beams

Depending on the intended use of the product, the corresponding warning sign stickers must be placed on the product.

3 Functional description

3.1 OMNIS Dosing Module – Overview

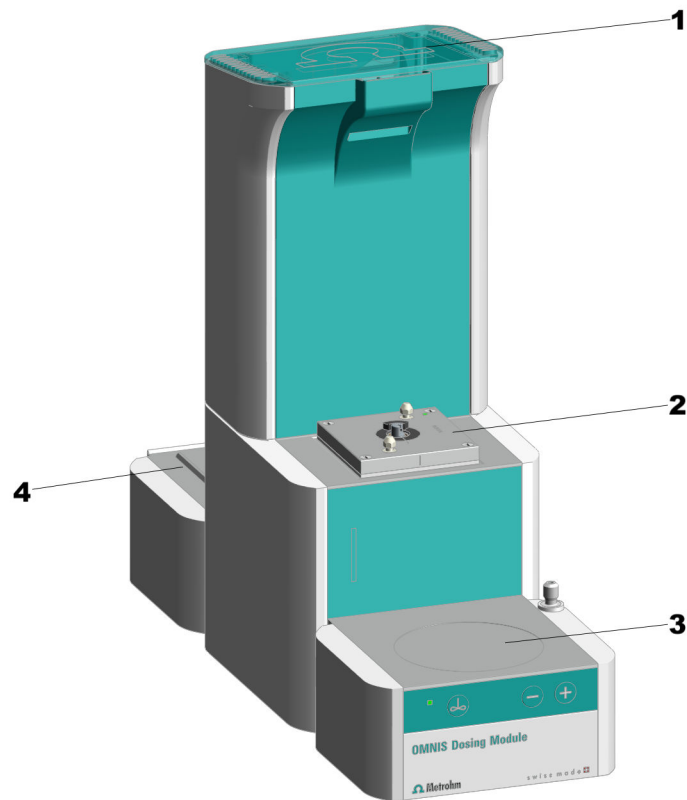

Figure 1 OMNIS Dosing Module – Front

1 Lid

2 Dosing drive

3 Magnetic stirrer
Optional, can be retrofitted.

4 Platform
For chemical bottle.

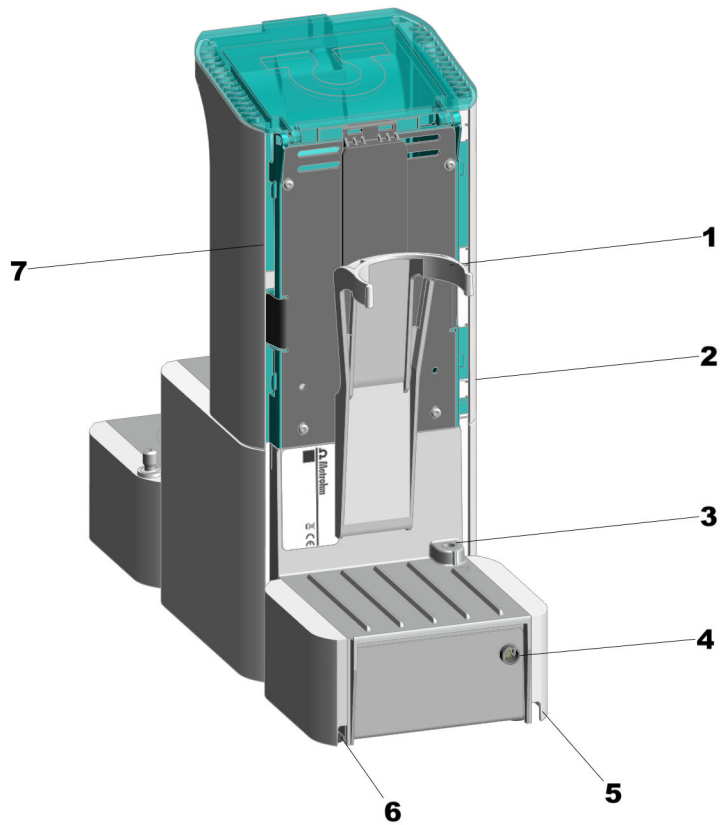

Figure 2 OMNIS Dosing Module – Rear

<p>1 Bottle holder</p>	<p>2 Cable guide On the side to the right. For Liquid Adapter cable.</p>
<p>3 MSI connector MSI = Metrohm Solution Identification. Connection socket for Liquid Adapter cable.</p>	<p>4 MDL connector MDL = Metrohm Device Link. Connection socket for the connecting cable to the basic unit.</p>
<p>5 Cable guide Bottom right.</p>	<p>6 Cable guide Bottom left.</p>
<p>7 Cable guide On the side to the left. For rod stirrer cable or electrode cable.</p>	

3.1.1 Magnetic stirrer – Overview

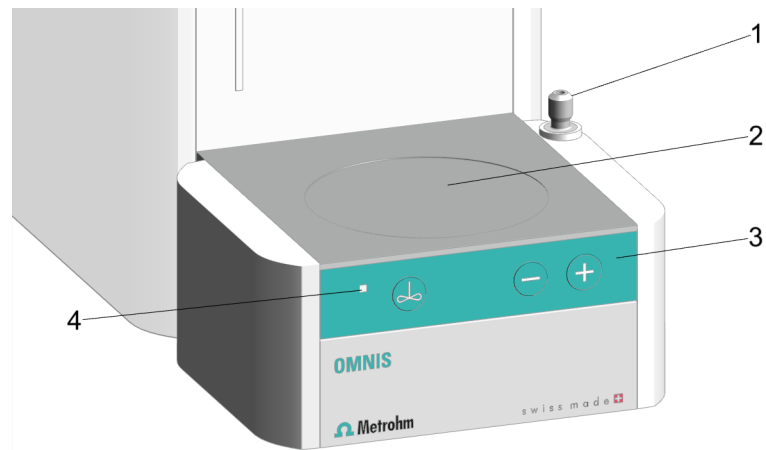

Figure 3 Magnetic stirrer – Overview

1 Stand attachment

2 Stirring area

3 Control bar

4 Status display
LED. Multi-colored



3.1.2 Magnetic stirrer with accessories – Overview

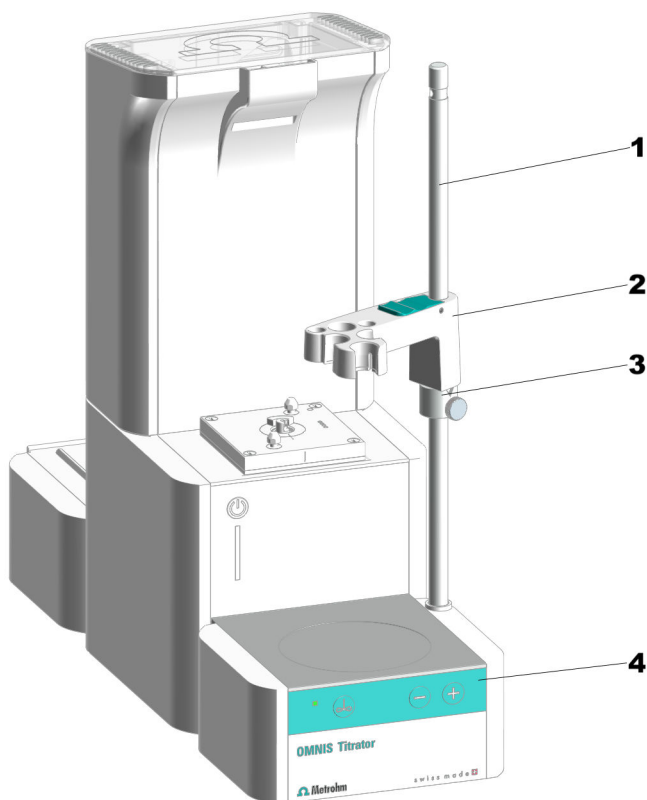

Figure 4 Magnetic stirrer with accessories – Overview

1	Support rod	2	Electrode holder
3	Clamping ring	4	Control bar

i The support rod is grounded. The OMNIS Titrator and OMNIS Titration Module have a hole in the support rod that serves as earth contact for a banana plug (4 mm).

3.1.3 Dosing unit – Overview

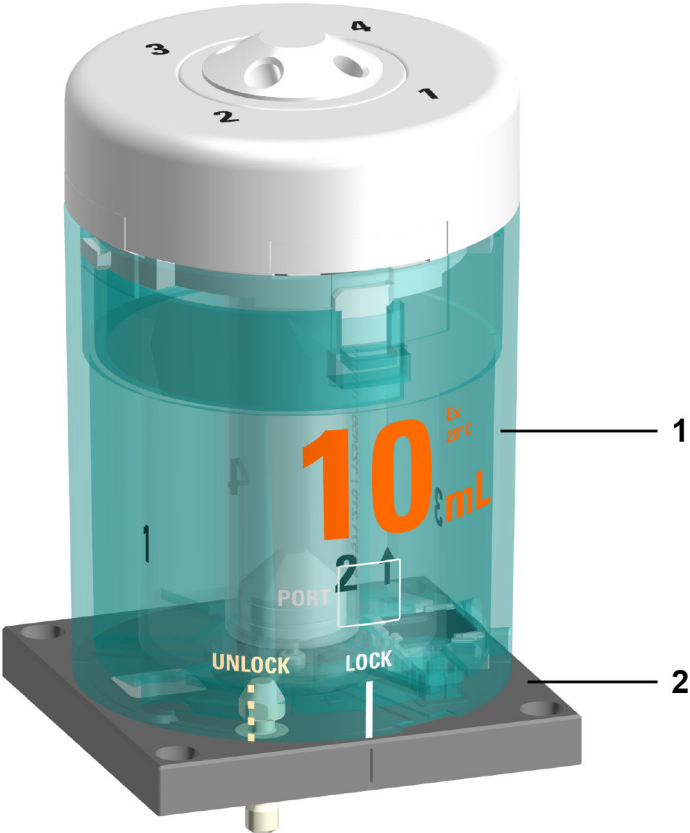

Figure 5 Dosing unit – Overview

1 Cylinder unit
Available with various volumes

2 Dosing drive
Not in scope of delivery

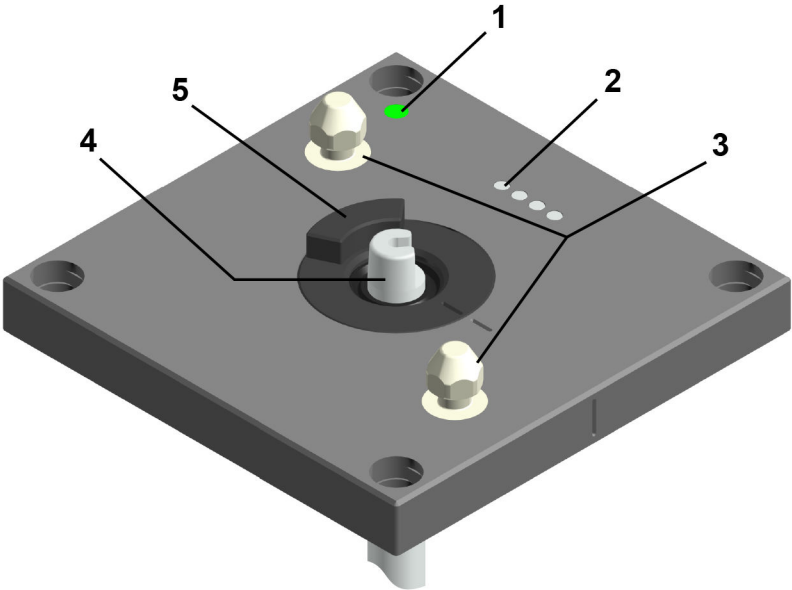

Figure 6 Dosing drive – Overview

- | | |
|--|---|
| 1 Status display
LED. Multi-colored | 2 Contact pins
For communicating with the cylinder unit |
| 3 Twistlocks
For locking the cylinder unit | 4 Piston rod
For moving the dosing piston |
| 5 Valve coupling | |



3.1.3.1 Cylinder unit OMNIS – Overview

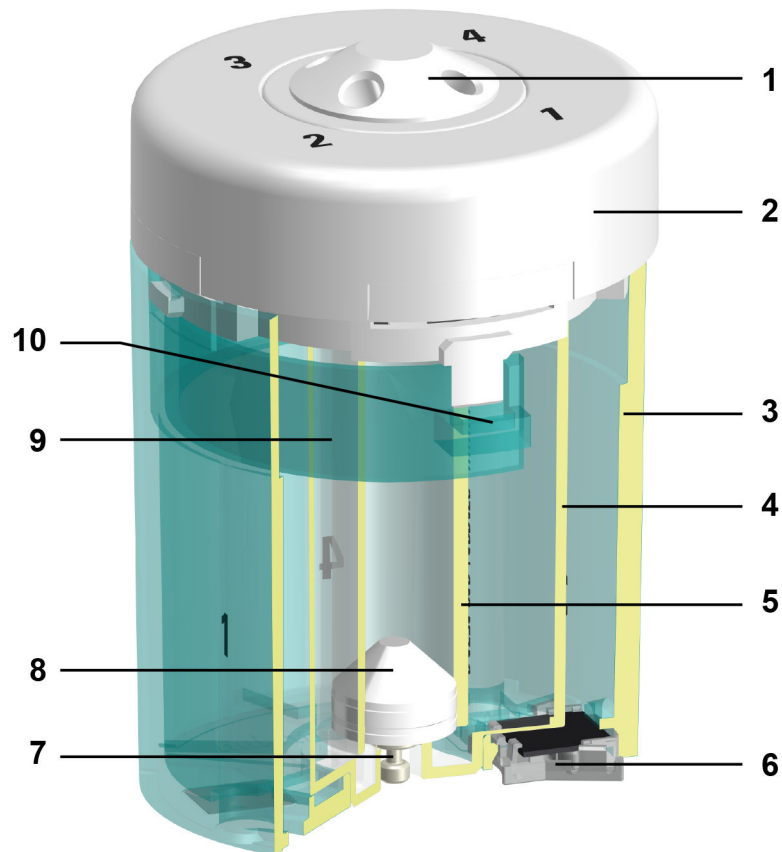

Figure 7 Cylinder unit – Overview

1	Distributor with 4 ports	2	Cylinder top piece
3	Cylinder housing	4	Centering tube
5	Cylinder	6	Data chip
7	Piston stopper	8	Dosing piston
9	Spring clip	10	Unlocking button

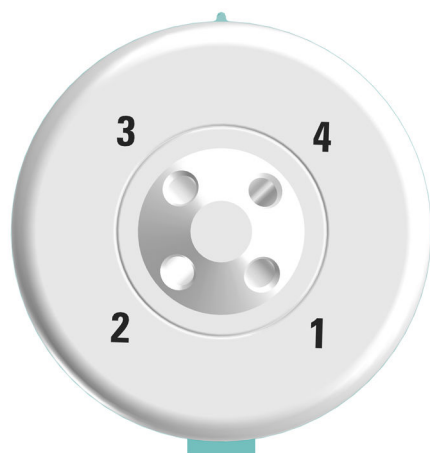

Figure 8 Cylinder unit – Overview from above

The following table shows the standard use of the 4 ports. The use of the ports can be changed in the OMNIS Software.

Port	Use	Connecting or sealing with
1	Dosing	Dosing tip
2	Filling the cylinder	Chemical bottle
3	Not used	Stopper
4	Not used	Stopper

3.1.4 Bottle unit – Overview

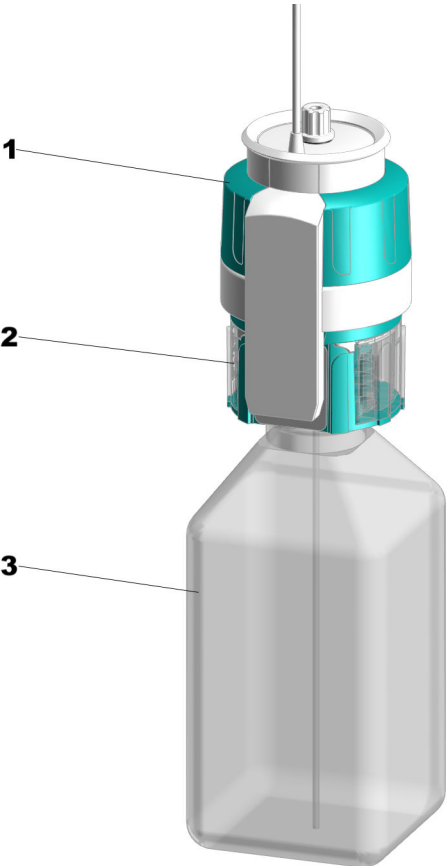

Figure 9 Bottle unit

-
- | | |
|-------------------------------|-------------------------------|
| 1 OMNIS Liquid Adapter | 2 Bottle cap multi-use |
| 3 Chemical bottle | |
-



3.1.4.1 OMNIS Liquid Adapter – Overview

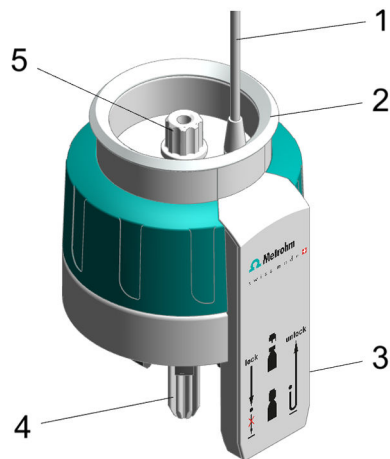

Figure 10 OMNIS Liquid Adapter – Parts

1 Cable	2 Status display
3 RFID reader	4 Aspiration tube Part of 6.01600.xxx
5 Tubing adapter Part of 6.01600.xxx	



3.1.4.2 Bottle cap multi-use – Overview

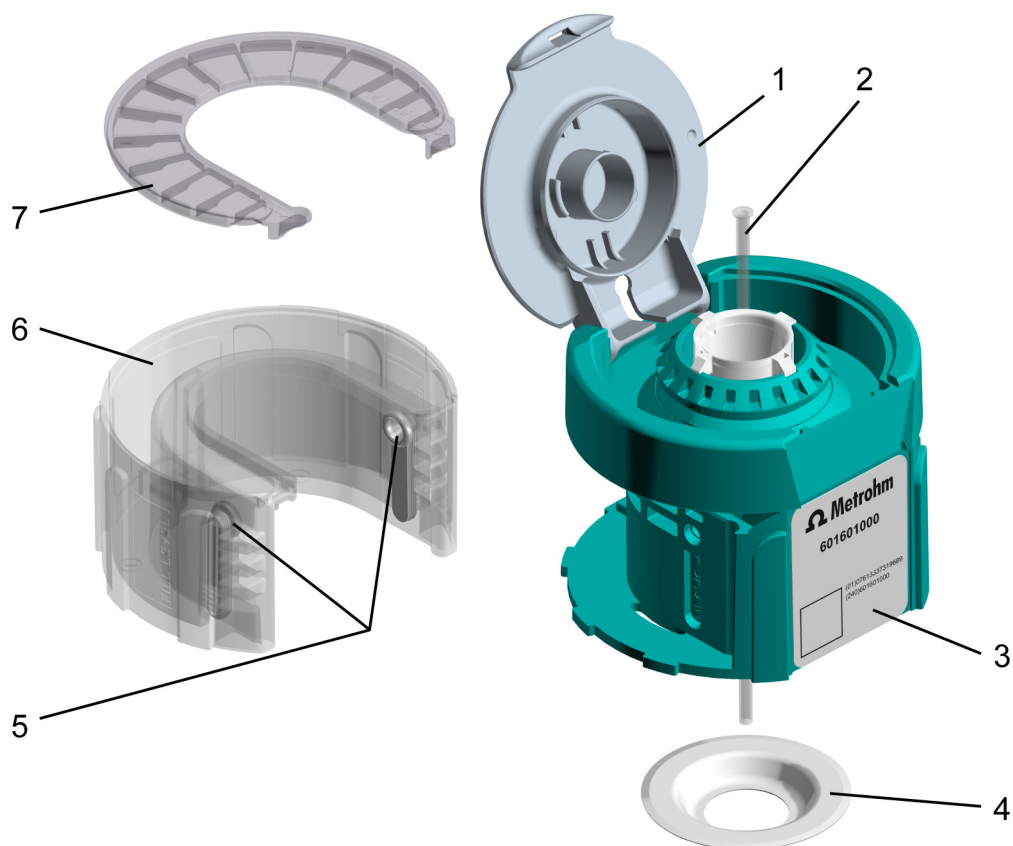

Figure 11 Bottle cap multi-use, complete (6.01601.000)

1 Flip-top lid	2 Aspiration tubing Aspiration tubing (6.1819.020)
3 RFID tag RFID chip for contact-free data transmission.	4 PTFE sealing ring PTFE sealing ring (6.02701.010)
5 Absorption cartridge insert (2 pieces)	6 Absorption cartridge housing
7 Absorption cartridge lid	5–7 Absorption cartridge, complete Absorption cartridge, complete (6.02701.000)



3.1.5 Volumetric Karl Fischer titration cell – Overview

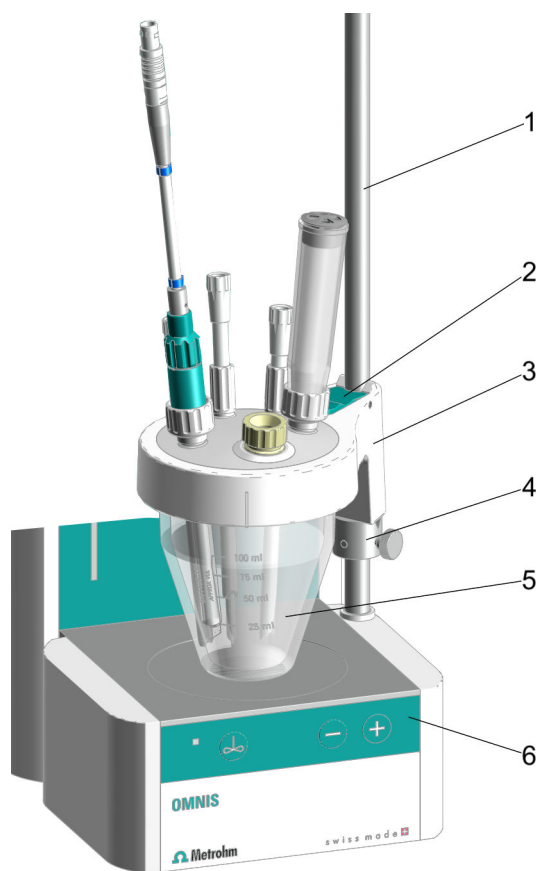

Figure 12 Installed volumetric Karl Fischer titration cell – Overview

1	Support rod	2	Locking lever
3	Titration vessel lid	4	Clamping ring
5	Titration vessel	6	Control bar for magnetic stirrer

3.2 OMNIS Dosing Module – Function

The OMNIS Dosing Module is a module for dosing liquids. It only works together with an instrument that has an electrical and a network connection.

The OMNIS Dosing Module is equipped with the following functional units:

- Interface for connecting an instrument with an electrical and a network connection.
- Dosing unit with an interchangeable cylinder unit.
- One magnetic stirrer, depending on the product version.
- Bottle unit with reagent detection.
- Cable guides
Cable guides are located at the rear and on the base of the OMNIS Dosing Module. The OMNIS Liquid Adapter cable can be guided to the connection socket in the cable guide on the right-hand side. The cable of a rod stirrer can be guided in the lateral and bottom cable guides on the left-hand side to the connection socket at the rear of the instrument.

3.2.1 Magnetic stirrer – Functional description

The magnetic stirrer ensures that the sample is well mixed. The stirring rate can be adjusted depending on the amount and viscosity of the sample. The magnetic stirrer is operated via the instrument control bar or via the OMNIS Software.

3.2.2 Dosing unit – Function

Software control of the dosing unit can be used for accurate dosing of liquid volumes.

The dosing unit is comprised of the following units:

- Dosing drive
- Cylinder unit

The dosing drive is permanently installed in the housing of the instrument. The dosing drive is controlled via the OMNIS Software and is responsible for the accurate dosing of the solution.

If the cylinder unit is placed on top of the dosing drive, the dosing drive assumes responsibility for the following functions:

- **Raising and lowering the dosing piston:**
Solution is aspirated if the dosing piston is lowered. The cylinder fills up.
Solution is dosed if the dosing piston is raised. The cylinder empties.

3.2.3.1 OMNIS Liquid Adapter – Functions

The basic principle

There is no fixed connection between the OMNIS Liquid Adapter and the chemical bottle that must be loosened when changing bottles. This means that you can transfer the OMNIS Liquid Adapter without difficulty from one bottle to another.

Liquid transfer

The liquid transfer is the responsibility of an aspiration tube installed in the OMNIS Liquid Adapter. When you place the OMNIS Liquid Adapter on the bottle, the aspiration tube presses on the aspiration tubing in the chemical bottle. A tightly sealed connection is made.

Contact-free data transmission

Information regarding the content of the chemical bottle is stored on an RFID tag on the bottle cap. The OMNIS Liquid Adapter has an RFID tag reader that reads this data.

The data cable fastened to the OMNIS Liquid Adapter transfers the information to the analyzer and to the software.

3.2.4 Volumetric Karl Fischer titration cell – Function

The volumetric Karl Fischer titration cell (KF titration cell) is a closed vessel for water content determination according to Karl Fischer that is fastened to the support rod of the magnetic stirrer.

The KF titration cell consists of:

- A titration vessel (different variants are available)
- A titration vessel lid (different variants are available, with and without homogenizer (Polytron PT 1300 D))

Seepage of moisture into the KF titration cell is prevented with seals and with the adsorber tube, which is filled with molecular sieve.



3.3 OMNIS Dosing Module - Indicators

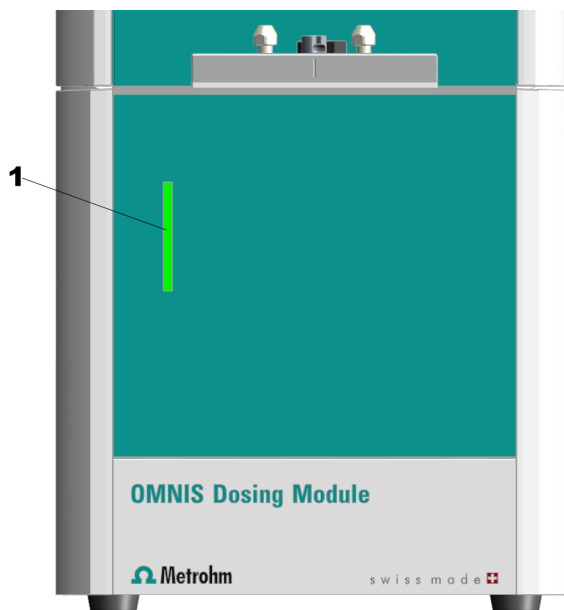

Figure 13 OMNIS Dosing Module - Indicators

1 Status display
Multi-colored



The status of the instrument is displayed with the status display (13-1) using different colors (see "System – Signals", chapter 3.4, page 24).



See also

System – Signals (chapter 3.4, page 24)

3.4 System – Signals

System components with status indicators show their operating status with colors and/or flashing patterns. The meaning of the colors and flashing patterns is explained in the following table.

Visual signal		Meaning
	LED lights up yellow.	System start or initialization
	LED flashes yellow (slowly).	Ready for connection setup or locking
	LED flashes yellow (fast).	Connection setup started or locking underway

Visual signal		Meaning
	LED lights up green.	Ready for operation
	LED flashes green (slowly).	In operation
	LED flashes red (fast).	Malfunction or error

Some system components only use part of the explained flashing patterns.

3.5 OMNIS Dosing Module - Interfaces

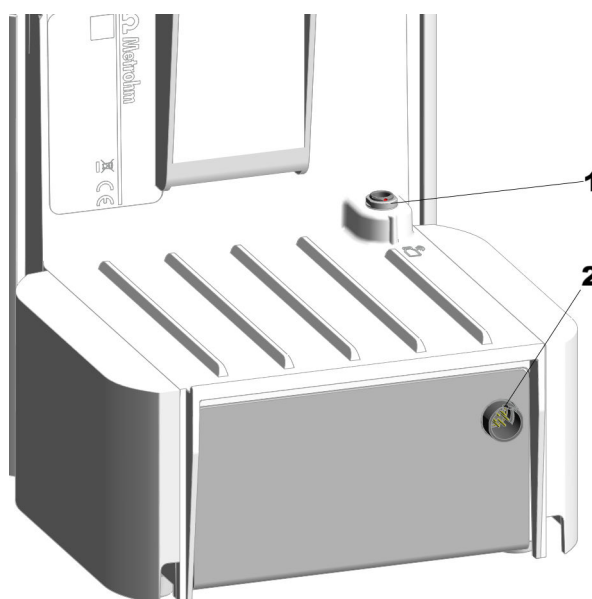

Figure 14 OMNIS Dosing Module - Interfaces

1 MSI connector

MSI = Metrohm Solution Identification. Connection socket for Liquid Adapter cable.

2 MDL connectors

MDL = Metrohm Device Link. Connection socket for connecting cable between OMNIS instruments.



4 Delivery and packaging

4.1 Delivery

Inspect the delivery immediately upon receipt:

- Check the delivery against the delivery note to ensure completeness.
- Check the product for damage.
- If the delivery is incomplete or damaged, contact your regional Metrohm representative.

4.2 Packaging

The product and accessories are supplied in protective special packaging. Keep this packaging to ensure safe transportation of the product. If a transport locking device is present, keep this as well for future reuse.

5 Installation

5.1 Installation by Metrohm

As a basic rule, the installation of the system is carried out by the regional Metrohm service representative.

5.2 Setup location

The product is only suitable for operation indoors and may not be used in explosive environments.

The following requirements apply to the setup location:

- The room is well ventilated, protected against direct sunlight and excessive temperature fluctuations.
- The setup space is stable and free of vibrations. The setup space must be suitable for the dimensions and weight of the components (see Technical specifications).
- All cables and connectors are accessible during operation. The cables are safely installed (no tripping hazards).
- The workplace is ergonomically designed and ensures trouble-free operation of the product.

5.3 Mounting the electrode parking station

Electrodes or storage vessels of electrodes can be placed in the electrode parking station. The electrode parking station can be mounted to either side of the instrument.

Required accessories:



Electrode parking station (6.02005.010)

1

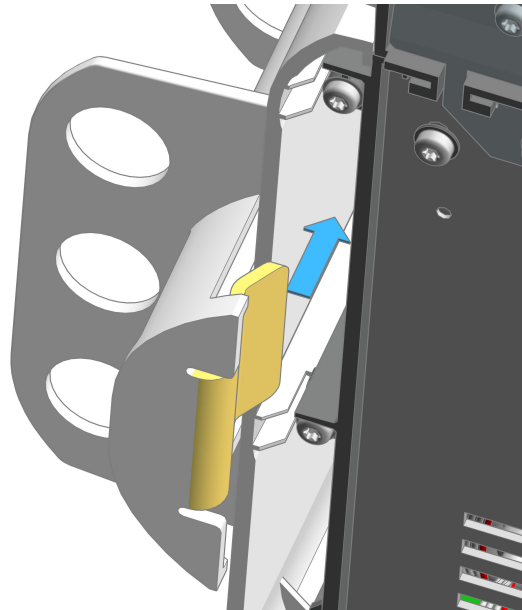

Tilt the OMNIS product to the side. Insert the stand of the electrode parking station into the side panel.

2

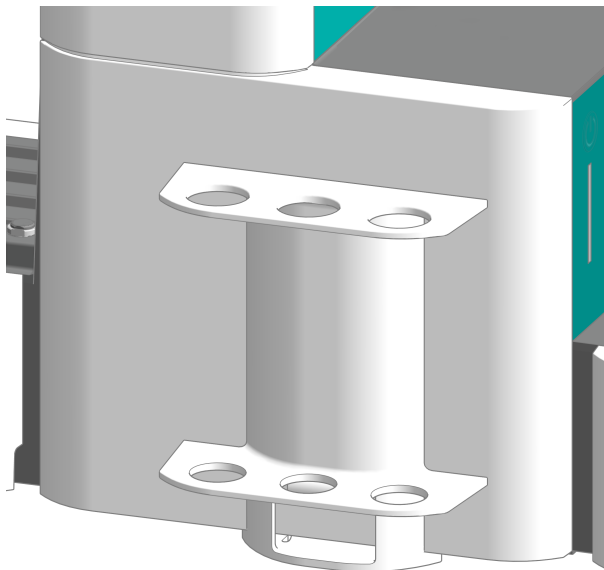

Place the OMNIS product in an upright position. Push the electrode parking station as far as it will go in the direction of the instrument's back panel.

Make sure that nothing is canted and that the corners of the electrode parking station do not protrude the side panel.

5.4 Attaching the cylinder unit OMNIS

i Default settings for the ports 1 and 2

Port 1 is defined as dosing port and port 2 as fill port in the data chip default settings of the cylinder unit. The following instructions describe the default setting.

If the ports should be used differently from the default setting, adjust the ports in the OMNIS Software in **Properties** ► **Specific data**.

Preparing for attaching

- 1 Open the **Manual control** of the dosing unit in the OMNIS Software, see [software help](#).
- 2 Start the **Exchange position** function.

Attaching the cylinder unit

i These instructions describe the default installation as defined in the OMNIS Software.

Prerequisite:

- Dosing drive: Valve coupling and piston rod are in the exchange position (port 2 is set).
- Cylinder unit: The piston stopper is flush with the base of the cylinder housing. The centering tube is in the correct position.

Required accessories:

- Wrench (6.2739.000)
- 2 FEP tubings (6.1805.100)
- Titration tip (6.1543.200)

1 Aligning the cylinder unit

Rotate the cylinder unit until the marking with the label **UNLOCK** is in line with the marking on the dosing drive.



2

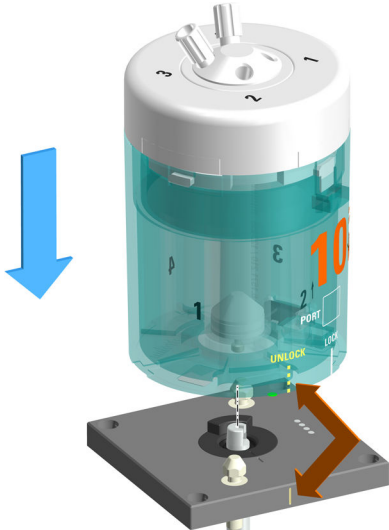

Set the cylinder unit down onto the two twistlocks straight from above.

3 Locking the cylinder unit

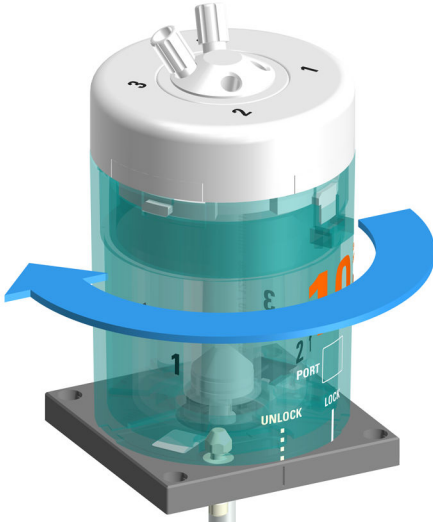

Rotate the cylinder unit to the left until it stops.
Use the marking with the label **LOCK** as a guide.



4 Mounting the tubings

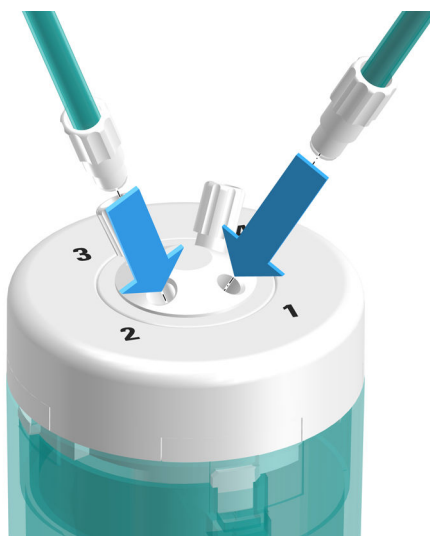

Tighten an FEP tubing (6.1805.100) into port 1.

This FEP tubing is used as dosing tubing. Tighten the other end to the titration tip (6.1543.200).

5 Tighten the other FEP tubing (6.1805.100) into port 2.

This FEP tubing is used as filling tubing. Tighten the other end to the OMNIS Liquid Adapter.

6 Firmly tighten the tubing with the wrench (6.2739.000).

See also

Cylinder unit OMNIS – Overview (chapter 3.1.3.1, page 15)

5.5 Magnetic stirrer – Installing the accessories

Mounting the electrode holder

Accessories

- Support rod, 30 cm (6.2016.050)
- Clamping ring, 10 mm (6.2013.010)
- Electrode holder (6.02005.000)

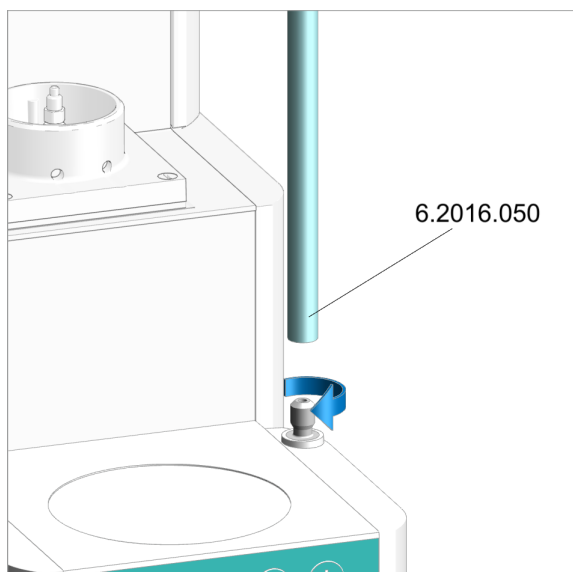

Mounting the support rod

Screw the support rod onto the stand attachment .

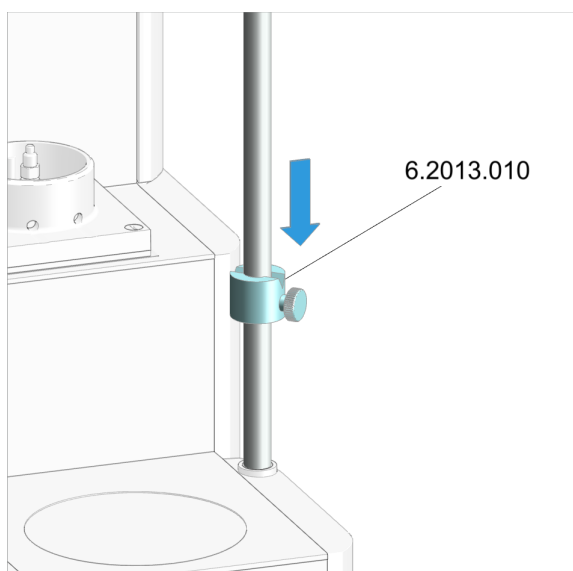

Mounting the clamping ring

Push the clamping ring over the support rod with the indent facing upward.

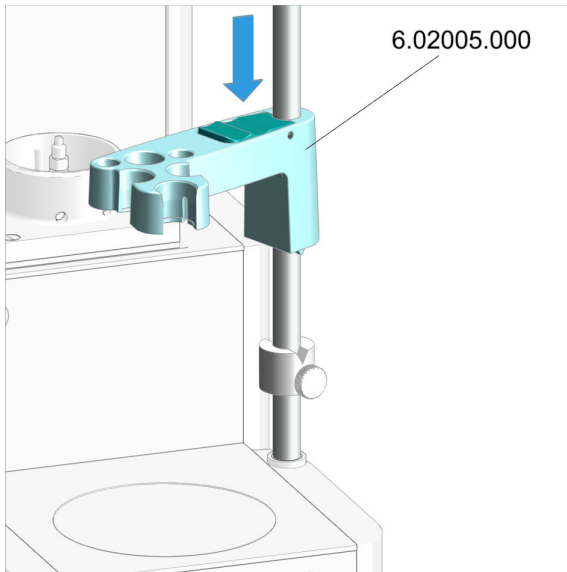

Mounting the electrode holder

1. Press the green locking lever on the electrode holder.
2. Push the electrode holder over the support rod.
3. To fix in place, release the green locking lever at the desired height.

The electrode holder is fixed in place.

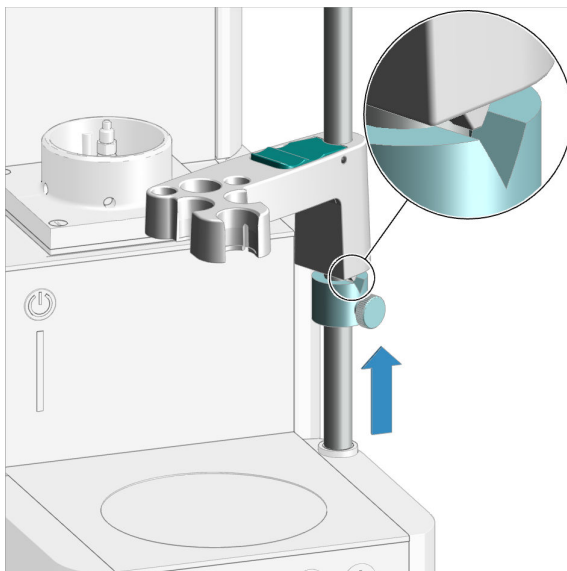

i The clamping ring is used as the lower stop for the electrode holder. The clamping ring prevents the electrode holder with the mounted electrode from being lowered too far.

1. Push the clamping ring under the electrode holder.
2. Rotate the clamping ring in such a way that the wedge on the electrode holder fits in the indent in the clamping ring.
3. Fix the clamping ring with the knurled screw in place at the desired height.



Preparing the magnetic stirrer for operation

Placing beaker and stirring bar

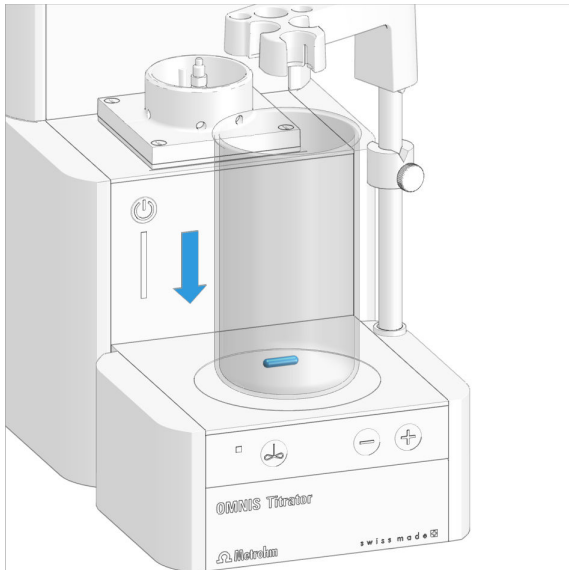

1. Place a 16 mm (6.1903.020) or 25 mm (6.1903.030) PTFE stirring bar in the sample beaker.
2. Place the sample beaker on the contact surface of the magnetic stirrer.

5.6 OMNIS Karl Fischer products – Replacing the adsorber material

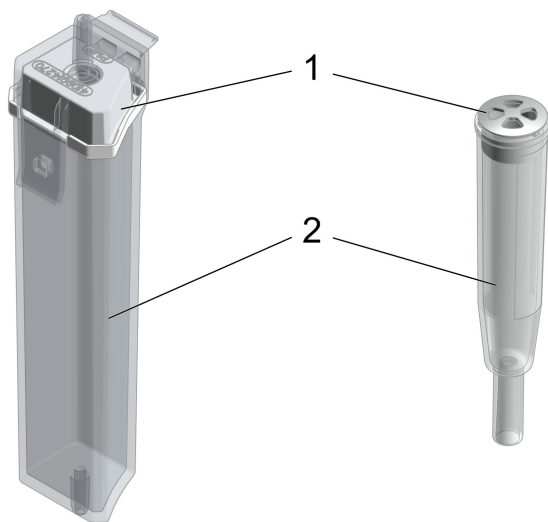
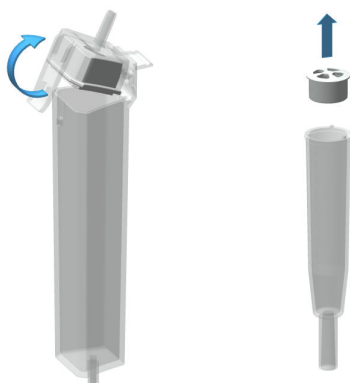

Figure 15 Adsorption cartridge of the OMNIS Solvent Module and adsorber tube for the KF titration cell

1 Lid

2 Housing

Replacing the adsorber material of the adsorption cartridge or adsorber tube



1. Removing the lid

Adsorption cartridge: Unlatch and remove the lid including the seal from the housing.

Adsorber tube: Remove the lid by pulling it out of the housing.

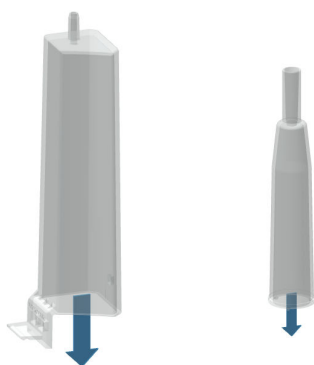

2. Removing the adsorber material

Remove the entire content.

This step is not necessary if the housing is empty.

i The molecular sieve can be regenerated at 300 °C in the drying oven, see <https://www.metrohm.com/en/support-und-service/faq-kft/>.

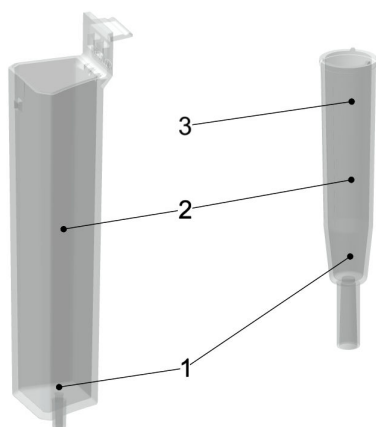

3. Filling the housing with adsorber material

1. Place a cotton plug loosely at the base of the housing. Do not pack the cotton too tightly as sufficient gas flow has to be possible.
2. Fill the housing with molecular sieve to approx. 1 cm under the housing edge.
3. **Adsorber tube:** Place a small cotton plug on the molecular sieve. Do not pack the cotton too tightly as sufficient gas flow has to be possible.

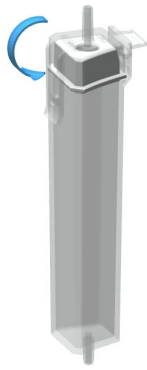

4. Sealing the housing with the lid

i Make sure that the sealing surface between the housing and the lid is clean and dry and that there are no residuals of filling material!

Adsorption cartridge: Hook the lid including the seal into the housing side and close it by clicking it into place.

Adsorber tube: Seal the housing with the lid.

i At average humidity, we recommend replacing the adsorber material approx. every 6 weeks.

An increase in drift indicates that the leak-tightness of the KF titration cell should be inspected and that the molecular sieve should possibly be replaced.

Hint:

Write the date on the adsorption cartridge when you replace the molecular sieve. With this, you always know when it was last filled or replaced.

5.7 OMNIS Dosing Module – Mounting the volumetric Karl Fischer titration cell

Setting up the volumetric KF titration cell

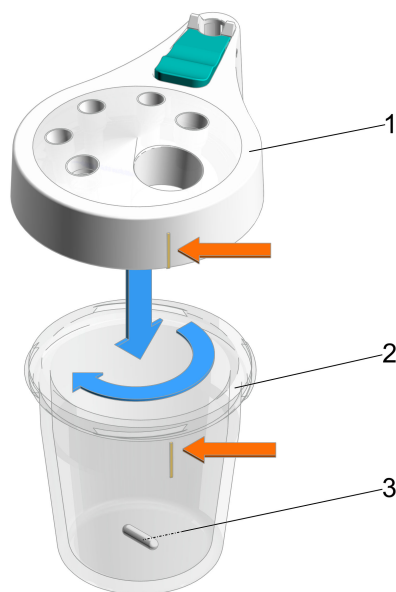

Figure 16 Preparing the volumetric KF titration cell

- | | |
|---|---|
| <p>1 KF titration vessel lid
(6.01405.010) or
for usage with homogenizer (6.01405.040)</p> | <p>2 KF titration vessel
20 – 90 mL (6.01406.220) or
50 – 150 mL (6.01406.250)</p> |
| <p>3 Stirring bar (without homogenizer!)
16 mm (6.1903.020) or
25 mm (6.1903.030)</p> | |

Assembling the volumetric KF titration cell

- 1** Select the KF titration vessel (16-2) of the required size and place a suitable stirring bar (16-3) inside.
- 2** Tighten the corresponding KF titration vessel lid (16-1) to the KF titration vessel.
 - i** When doing so, ensure that the color marking on the KF titration vessel aligns with the raised marking on the KF titration vessel lid.
The scale of the volumetric KF titration cell will thus face towards you.

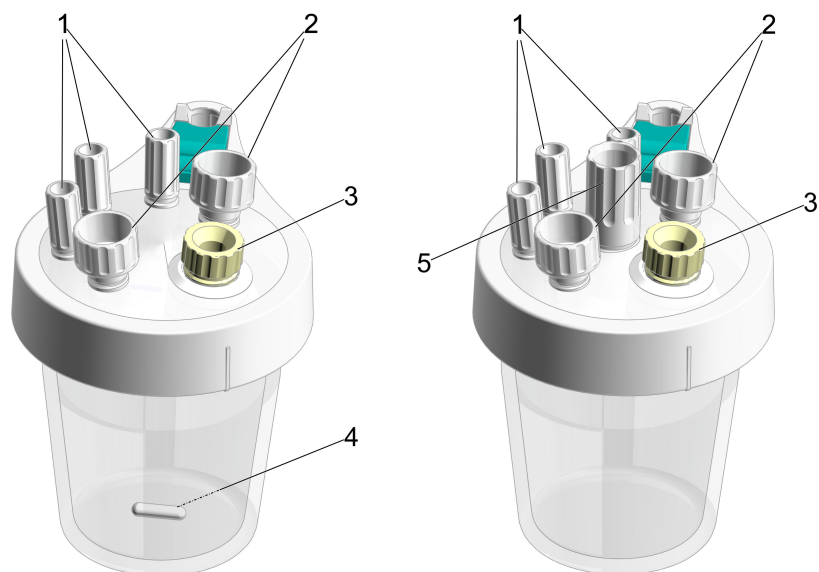

Figure 17 Volumetric KF titration cell (6.01405.010) – Volumetric KF titration cell for use with homogenizer (6.01405.040)

1 M10 screw nipple
(6.02709.010)

2 M12 screw nipple
(6.02709.030)

3 Septum stopper (or spoon for paste)

4 Stirring bar (without homogenizer!)
16 mm (6.1903.020) or
25 mm (6.1903.030)

5 Guide sleeve for homogenizer
Guide sleeve for Polytron PT 1300 D
(6.02709.050), further information see section (see "", page 46)

Preparing the volumetric KF titration cell

- 1** Insert the 3 screw nipples (17-1) in the M10 openings of the KF titration vessel lid.
- 2** Insert the 2 screw nipples (17-2) in the M12 openings of the KF titration vessel lid.

Equipping the volumetric KF titration cell

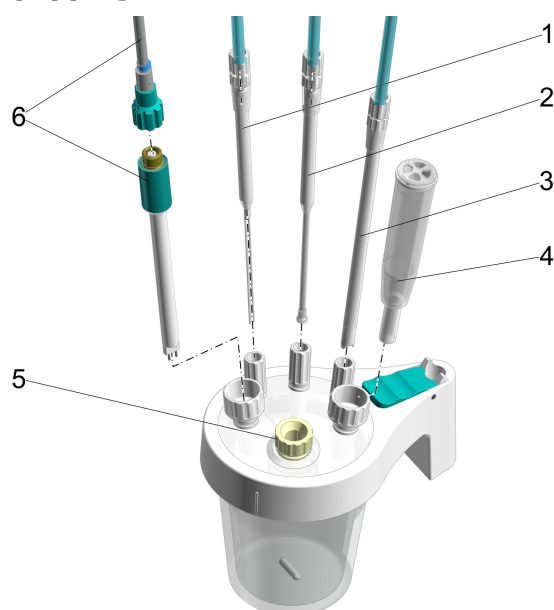

Figure 18 Volumetric KF titration cell – Equipping

1 Dosing tip (6.1543.110) with M8 tubing (6.1805.200)	2 Buret tip (6.01543.120) with M6 tubing (6.1805.100)
3 Aspiration tip (6.01543.000) with M8 tubing (6.1805.200)	4 Adsorber tube (6.01406.010)
5 Septum stopper with inserted septum (6.02709.020), stopper (6.02709.010) or OMNIS spoon for paste (6.02711.000)	6 Double Pt electrode (6.0338.100) with cable (6.02104.040)

Prerequisites:

- The volumetric KF titration cell is set up (*see ""*, page 37).
- The adsorber tube with lid (18-4) is filled with fresh molecular sieve, see (*see "OMNIS Karl Fischer products – Replacing the adsorber material"*, chapter 5.6, page 34).

- 1** Insert the dosing tip (18-1) in the M10 screw nipple on the left (17-1) and screw it tight.

The dosing tip should be located just above the stirring bar, but should not impede it.

- 2** Insert an M8 tubing in the M8 connector of the dosing tip (18-1) and screw it tight.

Mounting the volumetric KF titration cell on the OMNIS product (e.g. OMNIS Titrator)

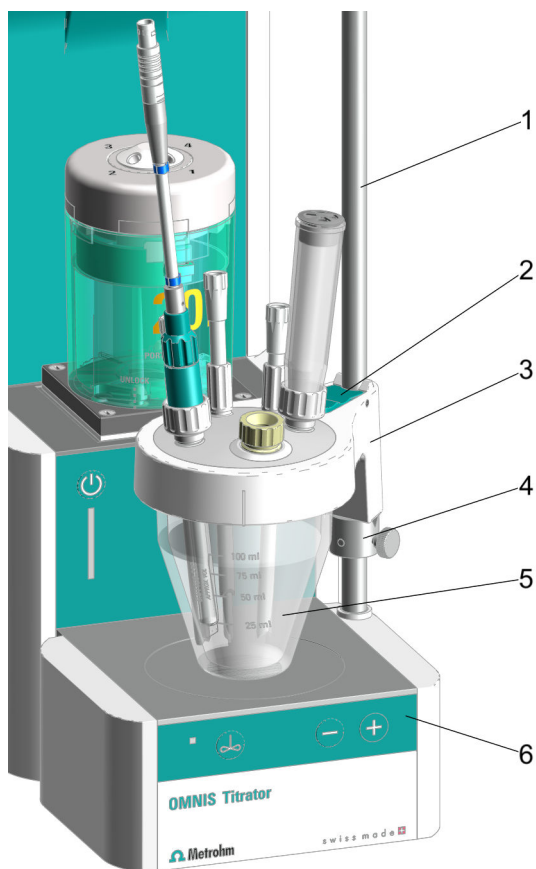

Figure 19 Mounting the volumetric KF titration cell on the OMNIS product – Overview

1	Support rod	2	Locking lever on the KF titration vessel lid
3	KF titration vessel lid (6.01405.010)	4	Clamping ring
5	KF titration vessel 20 – 90 mL (6.01406.220) or 50 – 150 mL (6.01406.250)	6	Magnetic stirrer

i If you want to mount the volumetric KF titration cell on the OMNIS product for use with a homogenizer, you can find additional information under [\(see "", page 46\)](#).

Prerequisites:

Mounting the joining elements for the volumetric KF titration cell on the OMNIS product (e.g. OMNIS Titrator) and OMNIS Solvent Module

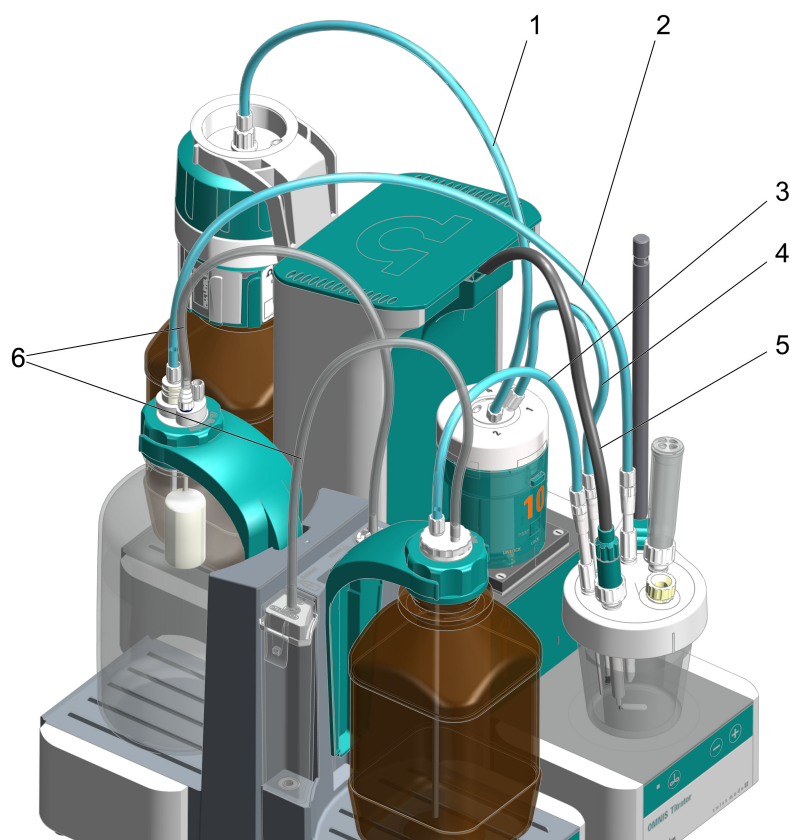

Figure 20 Connecting the KF titration cell with the OMNIS product and OMNIS Solvent Module

- | | |
|---|---|
| <p>1 M6 PTFE tubing from the fill port of the cylinder unit to the titrant bottle
(6.1805.100)</p> | <p>2 M8 PTFE tubing between aspiration tip and waste bottle (Waste)
Aspiration tip (6.01543.000) with M8 PTFE tubing (6.1805.200) leading to waste bottle (Waste)</p> |
| <p>3 M8 PTFE tubing between dosing tip and reagent bottle (Solvent)
Dosing tip (6.1543.110) with M8 PTFE tubing (6.1805.200) leading to the reagent bottle (Solvent)</p> | <p>4 M6 PTFE tubing between buret tip and dosing port 1 of cylinder unit
For adding the titrant via the buret tip (6.1543.200) with M6 PTFE tubing (6.1805.100) into the KF titration cell</p> |
| <p>5 Electrode cable leading to measuring module
Double Pt electrode (6.0338.100) with electrode cable (6.02104.040) leading to Measuring Module Analog</p> | <p>6 PVC tubings from the bottles to the OMNIS Solvent Module
(6.01804.210)</p> |

Prerequisites:

Connecting a double Pt electrode to the analog measuring module

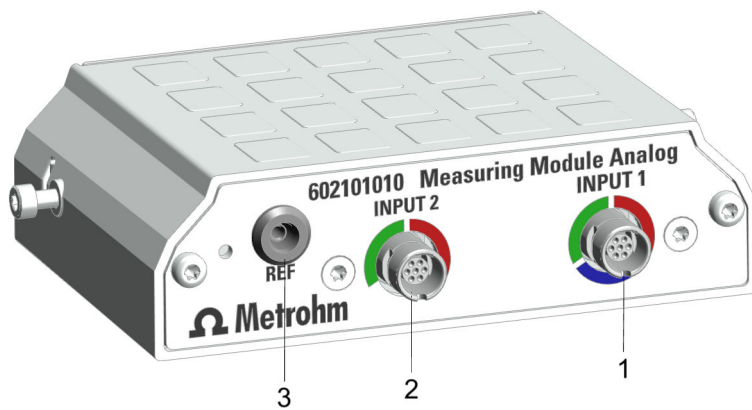

Figure 21 Measuring Module Analog – Interfaces

1 Connection socket INPUT 1

2 Connection socket INPUT 2

3 Connection socket REF

Prerequisites:

An electrode cable with blue coding is screwed tightly onto the double Pt electrode.

- 1** If applicable, mount an analog measuring module in the OMNIS product, see .
- 2** Connect the electrode cable with blue coding (20-1) to the socket **INPUT 1** , see .

i Note that only the socket **INPUT 1** can be used for KF titration, see blue marking!



Optional: Mounting the volumetric KF titration cell for use with homogenizer on the OMNIS product (e.g. OMNIS Titrator)

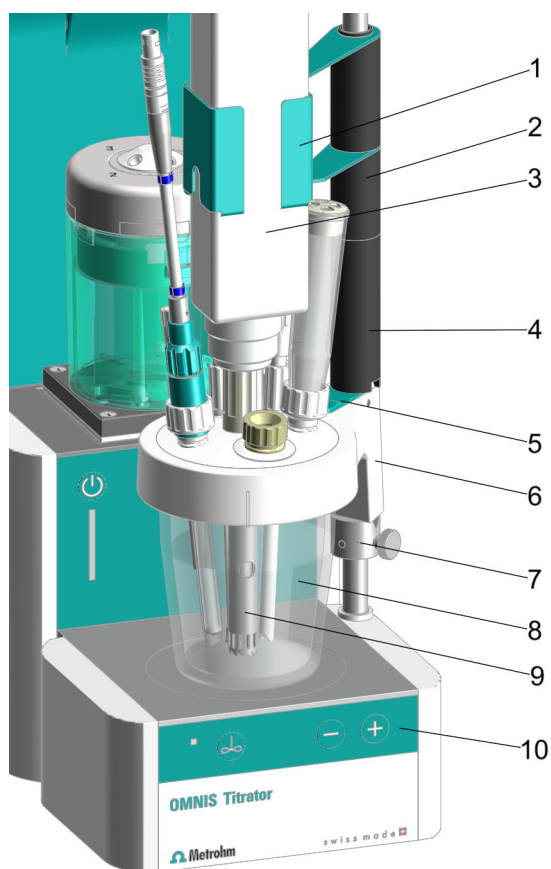

Figure 22 Mounting the volumetric KF titration cell for use with homogenizer on the OMNIS product – Overview

<p>1 Holder for homogenizer Holder for Polytron PT 1300 D (6.02008.010)</p>	<p>2 Spacer 35 mm</p>
<p>3 Polytron PT 1300 D (2.1360.100) with dispersing aggregate</p>	<p>4 Spacer 65 mm</p>
<p>5 Locking lever on the KF titration vessel lid</p>	<p>6 KF titration vessel lid for use with homogenizer (6.01405.040)</p>
<p>7 Support rod with mounted clamping ring</p>	<p>8 KF titration vessel 20 – 90 mL (6.01406.220) or 50 – 150 mL (6.01406.250)</p>
<p>9 Dispersing aggregate 125 mm (6.1912.000) or 157 mm (6.1912.010)</p>	<p>10 Magnetic stirrer</p>

i Make sure that no stirring bar is being used!

Prerequisites:

- The volumetric KF titration cell with KF titration vessel lid for use with homogenizer is prepared, see steps (*see ""*, page 38) and fully equipped including guide sleeve (not tightened) for homogenizer, see steps (*see ""*, page 39).
- The KF titration cell with KF titration vessel lid for use with homogenizer is mounted on the OMNIS product, see steps (*see ""*, page 41).

1 Push the spacer 65 cm (22-4) over the support rod with the indent facing downward.

While doing so, make sure that the wedge on the KF titration vessel lid fits in the indent on the spacer.

2 If you want to use the dispersing aggregate 157 mm (22-9), also push the spacer 35 cm (22-2) over the support rod.

3 Push the holder for homogenizer (22-1) over the support rod.

4 Insert the homogenizer (Polytron PT 1300 D) (22-3) with mounted dispersing aggregate (22-9) in the holder and at the same time insert it in the guide sleeve (17-5) for homogenizer in the KF titration vessel lid (22-6).

If the dispersing aggregate cannot be inserted into the guide sleeve easily, loosen the guide sleeve again.

5 Tighten the guide sleeve for homogenizer (17-5) until it seals.

6 Connect the homogenizer handset (22-3) to the control instrument of the homogenizer (Polytron PT 1300 D).

7 Connect the homogenizer (Polytron PT 1300 D) (22-3) with the RS-232 cable to the PC.

Hint:

We recommend using the dispersing aggregates as follows:

- **Dispersing aggregate 125 mm**
 - Applications with viscous samples
 - Samples with a diameter that is smaller than the diameter of the aggregate
 - Powders and salts that are difficult to dissolve



- **Dispersing aggregate 157 mm**
 - Applications with solid samples
 - Samples with a diameter that is bigger than the diameter of the aggregate

5.8 OMNIS titration system – Mounting the bottle unit

The bottle unit in an OMNIS system is comprised of the following elements:

- Chemical bottle
- OMNIS bottle cap
- OMNIS Liquid Adapter

Several chemical manufacturers offer chemical bottles with an OMNIS bottle cap single-use. An OMNIS bottle cap multi-use is available for other commercially available chemical bottles. If the chemical bottle does not feature a red OMNIS bottle cap, replace the original lid of the chemical bottle with a bottle cap multi-use.

Mounting the bottle unit

- 1 Assemble the OMNIS Liquid Adapter.
- 2 Mount and connect the OMNIS Liquid Adapter.
- 3 If the chemical bottle is not sealed with a red OMNIS bottle cap single-use,
 - prepare an OMNIS bottle cap multi-use.
 - Remove the original lid from the chemical bottle.
 - Screw the OMNIS bottle cap multi-use onto the bottle.
- 4
 - Lock the OMNIS Liquid Adapter with the chemical bottle.
 - Place the chemical bottle on the platform.

6 Start-up

6.1 Initial start-up by Metrohm

As a basic rule, the initial start-up of the system is carried out by the regional Metrohm service representative.

Usage of dosing tubing without antidiffusion valve

For usage without antidiffusion valve, do not immerse the dosing tubing in the sample solution.

There is a risk of back diffusion of the sample solution from the vessel into the tubing due to open tubing ends.

i The cylinder unit and its parts cannot be autoclaved. The sterility of a germ-free solution cannot be guaranteed.

7.2.1 Attaching the cylinder unit OMNIS

i Default settings for the ports 1 and 2

Port 1 is defined as dosing port and port 2 as fill port in the data chip default settings of the cylinder unit. The following instructions describe the default setting.

If the ports should be used differently from the default setting, adjust the ports in the OMNIS Software in **Properties** ► **Specific data**.

Preparing for attaching

- 1 Open the **Manual control** of the dosing unit in the OMNIS Software, see [software help](#).
- 2 Start the **Exchange position** function.

Attaching the cylinder unit

i These instructions describe the default installation as defined in the OMNIS Software.

Prerequisite:

- Dosing drive: Valve coupling and piston rod are in the exchange position (port 2 is set).
- Cylinder unit: The piston stopper is flush with the base of the cylinder housing. The centering tube is in the correct position.

Required accessories:

- Wrench (6.2739.000)
- 2 FEP tubings (6.1805.100)
- Titration tip (6.1543.200)

1 Aligning the cylinder unit

Rotate the cylinder unit until the marking with the label **UNLOCK** is in line with the marking on the dosing drive.



2

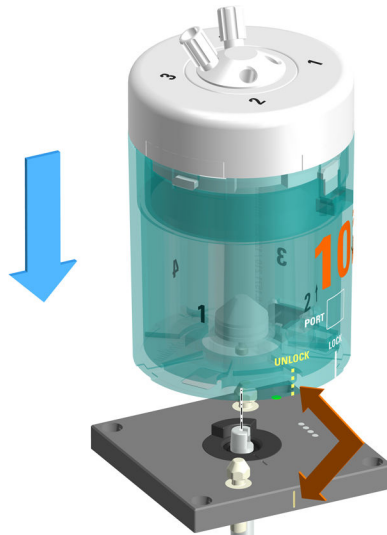

Set the cylinder unit down onto the two twistlocks straight from above.

3 Locking the cylinder unit

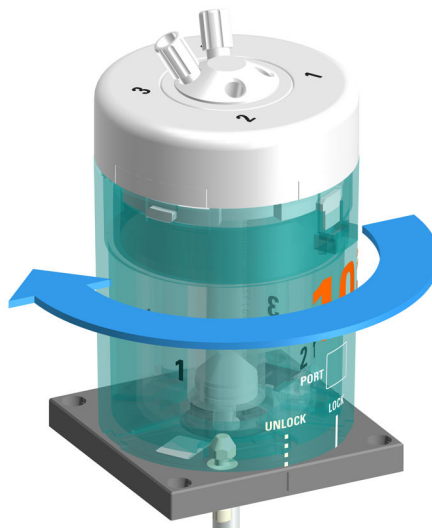

Rotate the cylinder unit to the left until it stops.
Use the marking with the label **LOCK** as a guide.

4 Mounting the tubings

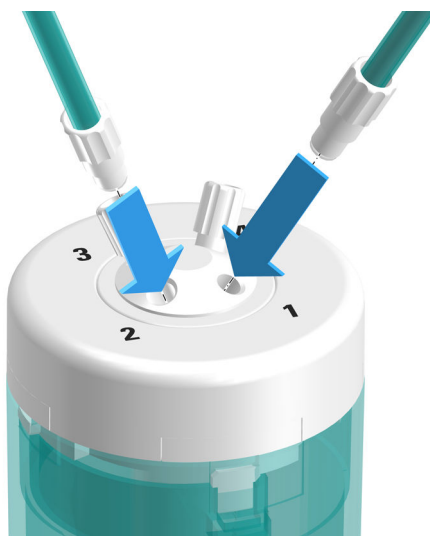

Tighten an FEP tubing (6.1805.100) into port 1.

This FEP tubing is used as dosing tubing. Tighten the other end to the titration tip (6.1543.200).

5 Tighten the other FEP tubing (6.1805.100) into port 2.

This FEP tubing is used as filling tubing. Tighten the other end to the OMNIS Liquid Adapter.

6 Firmly tighten the tubing with the wrench (6.2739.000).

See also

Cylinder unit OMNIS – Overview (chapter 3.1.3.1, page 15)

7.2.2 Removing the cylinder unit OMNIS

Preparing the removal

- 1 Open the **Manual control** of the dosing unit in the OMNIS Software, see [software help](#).
- 2 Start the **Empty** function.
- 3 Start the **Exchange position** function.

Removing the cylinder unit

Prerequisite:

- Dosing drive: Valve coupling and piston rod are in the exchange position (port 2 is set).
- Cylinder unit: The piston stopper is flush with the base of the cylinder housing. The centering tube is in the correct position.

1 Removing the tubing



Unscrew the dosing tubing and the filling tubing.

2 Unlocking the cylinder unit

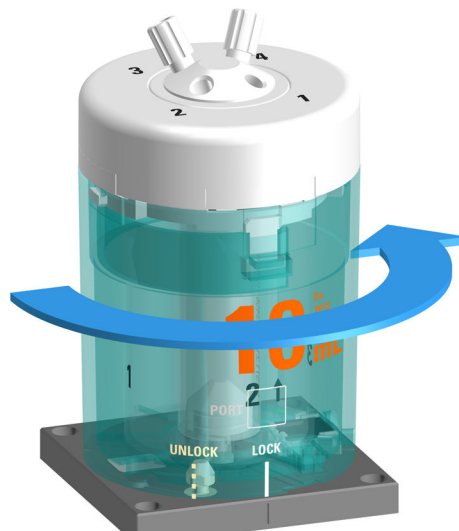

Rotate the cylinder unit to the right as far as the **UNLOCK** position.

3 Raising the cylinder unit

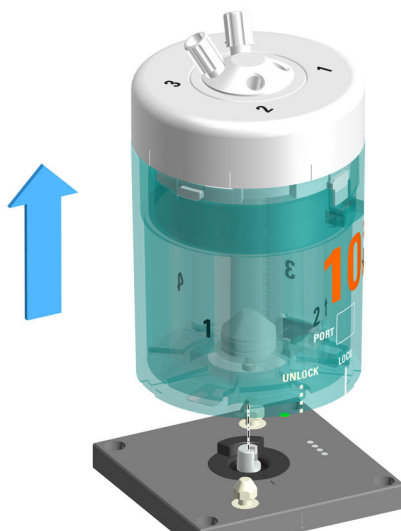

Raise the cylinder unit straight upwards.

See also

Cylinder unit OMNIS – Overview (chapter 3.1.3.1, page 15)

7.3 Magnetic stirrer – Operation

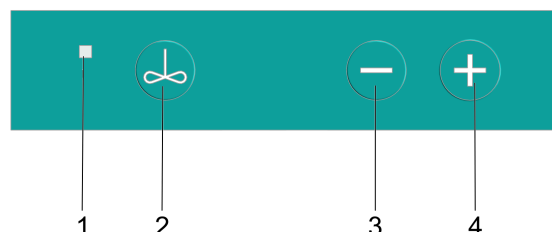

Figure 23 Magnetic stirrer – Control bar

1 Status display

Multi-colored

2 On/Off

(see "Switching the magnetic stirrer on and off", chapter 7.3.1, page 56)

3 Reduce stirring rate

(see "Setting the magnetic stirrer", chapter 7.3.2, page 57)

4 Increase stirring rate

(see "Setting the magnetic stirrer", chapter 7.3.2, page 57)

Other functions in the software

The following functions can be executed only with the OMNIS Software (see [OMNIS Help](#)):

- **Deactivate keys**
The magnetic stirrer can be operated only via the software.
- **Switch over the keys for the rod stirrer**
The keys on the magnetic stirrer operate the rod stirrer.
- **Set the stirring direction**

7.3.1 Switching the magnetic stirrer on and off

1 Switching the magnetic stirrer on

Press the  key.

The magnetic stirrer stirs with the most recently used stirring rate.

2 Switching the magnetic stirrer off

Press the  key once again.

The magnetic stirrer stops.

.....

 If the magnetic stirrer is running at a high stirring rate, reduce the stirring rate before switching it off.

As an alternative, switch the magnetic stirrer on and off in the OMNIS Software under *Manual control*.

7.3.2 Setting the magnetic stirrer

The stirring rate can be adjusted in 15 steps.

Prerequisite:

The magnetic stirrer is switched on.

1 Increasing the stirring rate in steps

Press the  key.

Each pressing of the key increases the stirring rate by 1 step. The current stirring rate appears in the OMNIS Software under **Manual control**.

2 Reducing the stirring rate

Press the  key.

Each pressing of the key reduces the stirring rate by 1 step. The current stirring rate appears in the OMNIS Software under **Manual control**.

Alternatively, the stirring rate can also be set in the OMNIS Software under *Manual control*.

 The stirring direction can be exclusively set in the OMNIS Software under **Manual control**.

WARNING

Electrical potential

Contact with electrical potential can cause serious injuries or death.

- Operate the product only if it is in perfect condition. The housing must also be intact.
- Only use the product with the covers fitted.
- Protect live components (e.g. power supply unit, power cord, connection sockets) against moisture.
- Always have maintenance work and repairs on electrical components carried out by a regional Metrohm service representative.

Prerequisite:

- The product is switched off and disconnected from the energy supply.

Required accessories:

- Cleaning cloth (soft, lint-free)
- Water or ethanol

1 Clean the surface with a damp cloth. Remove persistent contamination with ethanol.

2 Wipe the surface with a dry cloth.

3 Clean the connectors with a dry cloth.

8.3 Storing the cylinder unit OMNIS

 If the cylinder unit will not be used for a prolonged period of time, rinse and fill the cylinder with deionized water to prevent the valve disk and distributor disk from sticking together, especially when using:

- concentrated solutions that tend to crystallize
- EDTA solutions, ultrapure solvents and ultrapure water
- organic solvents
- alkaline (e.g. KOH in isopropanol), corrosive or high-concentration reagents

 If you are using water sensitive reagents, rinse the cylinder with solvent and then store it empty.

1 Soak the filling tubing in a bottle with rinsing liquid.

2 Open the **Manual control** of the dosing unit in the OMNIS Software, see [software help](#).

3 Execute the **Preparing** function 2 to 3 times with rinsing solution.

- 4 If the cylinder unit is to be stored empty,
 - remove the filling tubing from the bottle with rinsing solution and
 - start the **Empty** function.
- 5 Start the **Exchange position** function.
- 6 Store the cylinder unit at ambient temperature and protect it from direct sunlight.

i **Rinsing the cylinder unit automatically**

To automatically rinse the cylinder unit, download the method for automatically rinsing the cylinder unit as a template or create it yourself .

8.4 Cleaning the cylinder unit OMNIS

WARNING

Danger of poisoning and chemical burns from chemical hazardous substances

Poisoning and/or chemical burns by contact with aggressive chemical substances.

- Use only detergents that do not cause any unwanted side reactions with the materials to be cleaned.
- Clean contaminated surfaces.
- Wear protective equipment.
- Use exhaust equipment when working with vaporizing hazardous substances.
- Dispose of chemically contaminated materials (e.g. cleaning material) properly.

CAUTION

Instrument damage from aggressive chemical hazardous substances

Damage of the instrument or malfunction through contact with aggressive chemical substances.

- Clean up spilled liquids and solids immediately.
- Use protective grounding when working with highly flammable chemical substances and gases.
- If you suspect that chemical substances have gotten into the instrument, disconnect the instrument from the energy supply. Then, notify Metrohm Service.

i The cylinder unit requires appropriate care. Excess contamination of the cylinder unit results in malfunctions and a reduction in the service life.

Prerequisite:

The cylinder unit has been removed from the dosing drive. (see *"Removing the cylinder unit OMNIS", chapter 7.2.2, page 53*)

1 Cleaning the cylinder housing

 The cylinder housing is not dishwasher proof.

Clean the cylinder housing with lukewarm water and dishwashing detergent.

2 If the cylinder top piece is stuck, place the cylinder unit with the cylinder top piece facing down in warm water (possibly with a little dishwashing detergent) for at least 30 minutes.

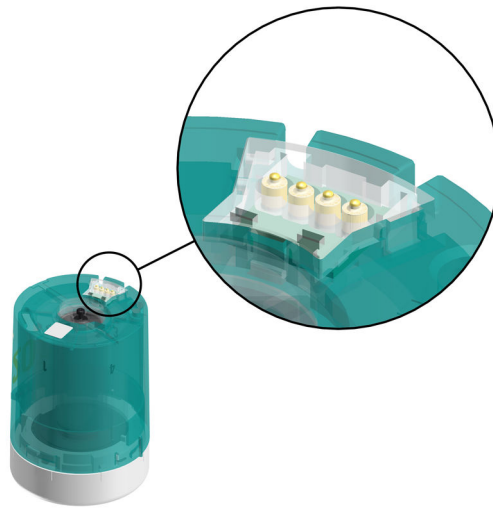
3 Cleaning the electrical contacts of the cylinder unit

If the electrical contacts are only lightly contaminated, clean the electrical contacts with a cloth moistened with water.

- 4** If the electrical contacts are heavily contaminated,
- add dishwashing detergent or ethanol to the moist cloth and clean the electrical contacts or
 - clean the electrical contacts in an ultrasonic bath with a little dishwashing detergent or ethanol.

Do not exceed 50 °C when drying. Use compressed air if necessary.



5 Cleaning the electrical contacts of the dosing drive

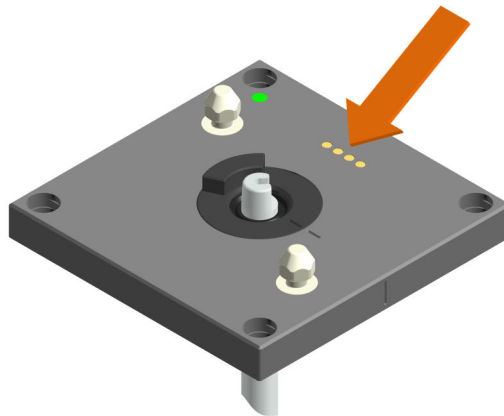

- If the electrical contacts are only lightly contaminated, clean the electrical contacts with a cloth moistened with water.
- If the electrical contacts are heavily contaminated, add dishwashing detergent or ethanol to the moist cloth and clean the electrical contacts.

8.5 Cleaning the OMNIS Liquid Adapter

Cleaning the aspiration tube

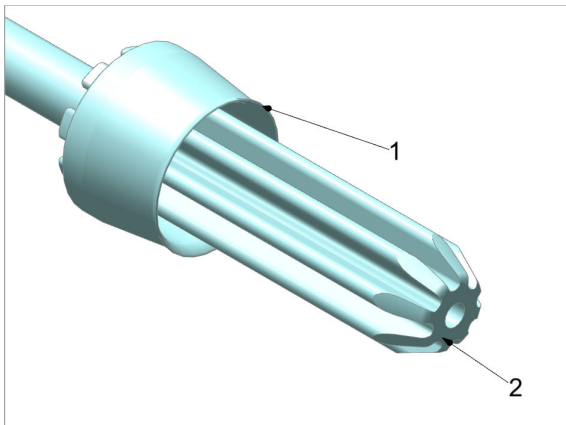

1. Rinse the aspiration tube thoroughly under running water.
Rub dry with a lint-free, damp cloth.
2. Check whether the sealing lip (**1**) and the sealing surface (**2**) are clean and intact.

If the sealing lip or the sealing surface of the aspiration tube can no longer be cleaned, mount a new aspiration tube.

Cleaning the OMNIS Liquid Adapter

CAUTION

Instrument damage through inward seepage of liquid

Property damage to the instrument or malfunction through the inward seepage of liquids (e.g. when cleaning).

The instrument is not resistant to splash water. Water can seep into the interior during cleaning and cause damage (e.g. to the electronics).

- Do not clean the instrument under running water.
- Do not use a wash bottle to clean the instrument.
- Only wipe the instrument thoroughly with a damp cloth.

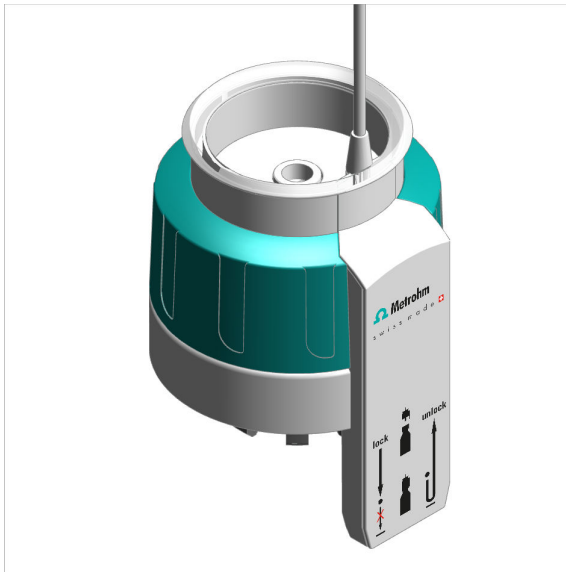

Wipe the OMNIS Liquid Adapter thoroughly from the outside with a damp cloth.

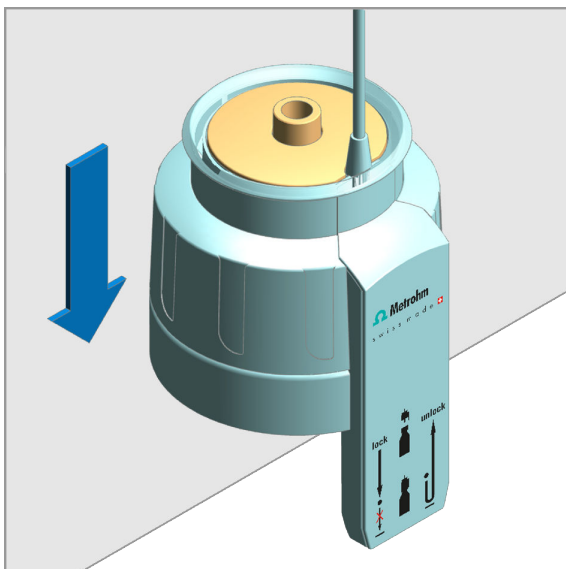

1. In order to access the lowered part better, set the OMNIS Liquid Adapter on a table edge. Push the OMNIS Liquid Adapter down and keep it pushed down. The lowered part rises.
2. Thoroughly wipe the surface and the slot for the aspiration tube with a damp cloth.
3. If the interior of the slot is contaminated, wipe it with a moistened cotton bud.
4. Release the housing of the OMNIS Liquid Adapter.



Contamination with organic substances

If the OMNIS Liquid Adapter is contaminated with organic substances, clean it with ethanol, methanol and/or isopropanol.

-  Do not use solvents that contain acetone to clean the OMNIS Liquid Adapter. Acetone will corrode the labels on the OMNIS Liquid Adapter.

9 Troubleshooting

Messages on malfunctions and errors are displayed in the control software or in the embedded software (e.g. on the display of an instrument) and contain the following information:

- Descriptions of causes of malfunctions (e.g. jammed drive)
- Descriptions of problems with the control (e.g. missing or invalid parameter)
- Information on how to solve the problem

System components with status display elements also indicate malfunctions and errors with a red flashing LED.

Troubleshooting on the product is often only possible with the control software or the embedded software (e.g. initializing, moving to a defined position).

See also

[System – Signals \(chapter 3.4, page 24\)](#)

10 Disposal

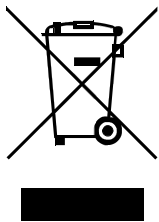

Properly dispose of chemicals and of the product to reduce negative effects on the environment and public health. Local authorities, waste disposal companies or dealers provide more detailed information on disposal. Observe the WEEE EU directive (WEEE = Waste Electrical and Electronic Equipment) for the proper disposal of waste electronic equipment within the European Union.

11 Technical specifications

11.1 Ambient conditions

Nominal function range	+5 to +45 °C	at max. 80% relative humidity, non-condensing
Storage	+5 to +45 °C	

11.2 OMNIS Dosing Module – Energy supply

Nominal voltage	24 VDC
-----------------	--------

11.3 Magnetic stirrer – Energy supply

Nominal voltage	24 VDC	internal
-----------------	--------	----------

11.4 OMNIS Dosing Module – Dimensions

Measurements

<i>Width</i>	142 mm
<i>Height</i>	358 mm
<i>Depth</i>	
Without magnetic stirrer	284 mm
With magnetic stirrer	400 mm

Weight

<i>Type</i>	
Without magnetic stirrer	4.0 kg
With magnetic stirrer	4.7 kg



11.5 Magnetic stirrer – Dimensions

Measurements

<i>Width</i>	142 mm
<i>Height</i>	70 mm
<i>Depth</i>	116 mm

Weight	700 g
---------------	-------

11.6 OMNIS Dosing Module – Housing

Materials

<i>Lid</i>	PET	poly(ethylene terephthalate)
<i>Back panel</i>	AW-5754 H12/H22	aluminum, coated
<i>Base</i>	1.4301	high-grade steel
<i>Enclosure</i>	PBT	poly(butylene terephthalate)
<i>Front foils</i>	PET	poly(ethylene terephthalate), mat
IP degree of protection	IP 40	

11.7 Magnetic stirrer – Housing

Materials

<i>Cover</i>	PBT	poly(butylene terephthalate)
<i>Base</i>		chromium steel
<i>Enclosure</i>	PBT	poly(butylene terephthalate)
<i>Front foils</i>	PET	poly(butylene terephthalate), mat
IP degree of protection	IP 40	



11.8 OMNIS Dosing Module – Connectors specifications

Energy supply		via MDL
<i>Socket</i>		round plug
MDL	Metrohm Device Link	
Contacts	4	contact surfaces for cylinder unit

11.9 Display specifications

Status display	LED	multi-colored
-----------------------	-----	---------------

11.10 OMNIS Dosing Module – Liquid Handling specifications

Dosing drive		
<i>Dosing resolution</i>	100,000	steps per cylinder volume
<i>Dosing accuracy</i>	0.01%	typically, of the dosed volume with respect to the cylinder volume

11.11 Magnetic stirrer – Specifications

OMNIS product version		with attached magnetic stirrer
Adjustment range for rotational speed	+1 to +15	Rotation in counter-clockwise direction (seen from above)
	-1 to -15	Rotation in clockwise direction (seen from above)



Rotational speed change per step	120 rpm
Maximum rotational speed	1,800 rpm
Stirring bar lengths	8, 12, 16, 25, 30 mm

