



Application Note AN-PAN-1046

Online determination of anionic impurities in 50% NaOH and KOH

Process ion chromatography according to ASTM E1787

The basic chemicals industry is responsible for producing thousands of raw materials at very large scales. The industries downstream rely upon a certain level of chemical purity to manufacture their own goods, as certain impurities can cause major issues in various processes. During the production of the basic chemicals sodium and potassium hydroxide (NaOH and KOH), electrolysis with membrane cells of saturated brine solutions yields the product which is further concentrated by evaporation. Impurities from the salts used in the brine will also be concentrated.

Typically, this impurity analysis is performed offline using various hazardous chemicals with varying shelf-lives.

This Process Application Note is focused on monitoring anionic impurities in caustic soda and caustic potash. The **2060 IC Process Analyzer** is the perfect solution to perform the measurement described in ASTM E1787 online, ensuring quality product without the need for time-consuming, hazardous laboratory experiments.

INTRODUCTION

The production of caustic soda (sodium hydroxide, lye, NaOH) and caustic potash (potassium hydroxide, KOH) is extremely significant, as these are mainly used as precursors for many other chemicals used in all industries. For example, the pulp and paper industry is especially reliant on concentrated caustic soda for chemical pulping of wood in the Kraft process, and the agrochemical industry is heavily reliant on KOH. Caustic soda and caustic potash are produced alongside chlorine in the chlor-alkali process, which is explained in more detail in [AN-PAN-1005](#). In this process, chlorine and caustic soda (or potash) are produced via electrolysis of sodium chloride (or potassium chloride) brine, mainly with the membrane-cell technique [1]. Some production plants make both NaOH and KOH in the same cell room, though generally the brine circuits are kept separate to avoid time-consuming cleaning and purging

processes between the different brines. In both situations, the caustic product is concentrated to about 50 wt-% by two- or three-step evaporations before it is stored. This concentrated product contains impurities from the salts used which are undesirable in certain chemical purity grades needed for the subsequent production processes.

Typically, anionic impurities in 50 wt-% caustic soda or potash are determined by gravimetric or titration methods which require a variety of reagents with diverse shelf lives and hazards. In 2016, the **ASTM method E1787** was released, specifying ion chromatography (IC) to measure bromide (Br^-), chlorate (ClO_3^-), chloride (Cl^-), fluoride (F^-), nitrate (NO_3^-), phosphate (PO_4^{3-}), and sulfate (SO_4^{2-}) in concentrated NaOH or KOH solutions. Anions of primary interest are Cl^- , ClO_3^- , and SO_4^{2-} , as shown in [Figure 1b](#).

(a)

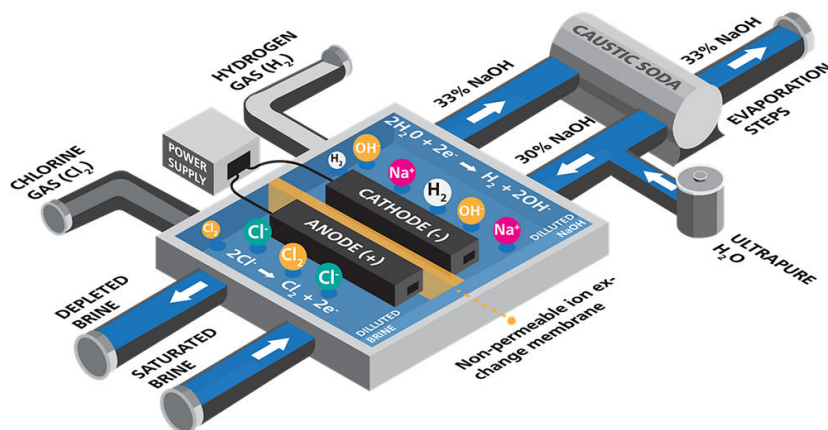

(b)

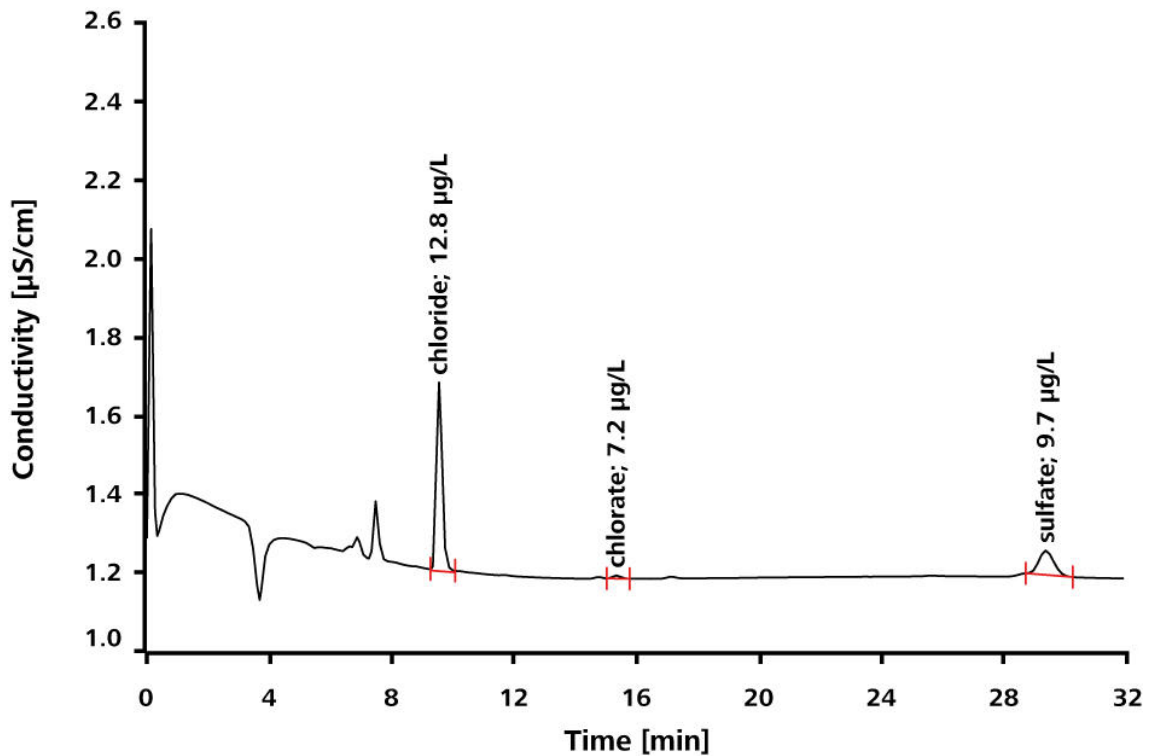

Figure 1. (a) Diagram of the membrane cell process used to produce concentrated NaOH and KOH alongside chlorine (source material: <http://www.eurochlor.org> [1]); (b) 100 μL injection of 50% KOH sample (diluted 1:10), using Metrohm Inline Sample Preparation (MISP) techniques for extra application flexibility.

The 2060 IC Process Analyzer from Metrohm Process Analytics (Figure 2) is ideal for fulfilling ASTM E1787. The analyzer is able to continuously measure and monitor anionic impurities in caustic soda and caustic potash in a robust housing suitable for such a process environment. Metrohm offers many fully automatic inline sample preparation techniques for ion chromatography, making analysis even more hands-off and flexible. Automated calibration guarantees excellent detection limits, high reproducibility, and excellent recovery rates.

The caustic stream is sampled frequently, giving up-to-date information about the status of the membrane cells. The 2060 IC Process Analyzer can provide an alarm if pre-set warning or intervention concentration limits are reached, helping to save costs by preventing irreparable damage due to membrane fouling and other problems. One 2060 IC Process Analyzer has the possibility to connect to up to 10 sample streams, meaning multiple cells with different end products could be monitored for impurities by a single instrument.



Figure 2. The Metrohm Process Analytics 2060 IC Process Analyzer, along with integrated liquid handling modules and several automated sample preparation options.

The 2060 IC Process Analyzer can run for extended periods in less-frequented areas as there is adequate space reserved for reagents, containers of ultrapure water and/or prepared eluent, and level sensors to alert users when liquid levels are low. By choosing a

built-in eluent module and optional PURELAB® flex 5/6 from ELGA® for continuous pressureless ultrapure water supply, the 2060 IC Process Analyzer can be configured to run even trace analyses autonomously.

APPLICATION

Concentrated KOH and NaOH samples can be analyzed according to ASTM E1787, with Metrohm Inline Sample Preparation techniques for extra

application flexibility. Analyte detection is by conductivity.

Table 1. Typical measurement parameters in concentrated caustic solutions * Some of the anionic impurities include bromide, chlorate, chloride, fluoride, nitrate, phosphate, and sulfate [2].

Parameters	Range [$\mu\text{g/g}$]
Anionic impurities *	0.1–1000

REMARKS

For sulfate quantification, it is essential to use perchloric acid (HClO_4) for the inline neutralization. An anion trap (A Trap 1) should be used in line with any ultrapure transfer water to ensure the highest

quality results. For high concentrations of chloride, potentiometric titration can be used. Metrohm Process Analytics offers potentiometric titration options for samples above 2 mg/L Cl^- .

CONCLUSION

The 2060 IC Process Analyzer from Metrohm Process Analytics can continuously measure and monitor anionic impurities in caustic streams according to ASTM E1787. Integrated with liquid handling

modules and automated sample preparation, the 2060 IC Process Analyzer makes calibration and validation as simple as pressing a button.

REFERENCES

- [1] How Are Chlorine and Caustic Soda Made? *Euro Chlor* 17.
[2] Standard Test Method for Anions in Caustic Soda and Caustic Potash (Sodium Hydroxide and Potassium

Hydroxide) by Ion Chromatography <https://www.astm.org/e1787-16.html> (accessed 2022-04-08).

BENEFITS FOR PROCESS ION CHROMATOGRAPHY

- Increased longevity of valuable company assets
- Monitor multiple sample streams (up to 10) for more savings per measurement point and results
- Fully automated diagnostics – automatic alarms for when samples are out of specification parameters



CONTACT

Metrohm Portugal
R. Frei Luis de Granada 14G
1500-680 Lisboa

vendas@metrohm.pt

CONFIGURATION



2060 IC Process Analyzer

The 2060 Ion Chromatograph (IC) Process Analyzer from Metrohm Process Analytics is based on the modular 2060 platform concept. This modular architecture enables the separation of the cabinets in different locations around a plant and the connection to up to 20 sample streams for time-saving sequential analysis at multiple areas inside of a plant.

This analyzer has no limits in terms of hardware, software, and applications customization. From continuous eluent production module, wet part modules for sample conditioning, and multiple IC detector blocks, the 2060 IC Process Analyzer has all the options for any industrial application.

The 2060 software is an «all-in-one» software solution that controls the analyzer to perform routine analysis, with different operation methods, time sheets, and trend charts. Furthermore, thanks to the variety of process communication protocols (e.g. Modbus or Discrete I/O), the 2060 software is programmable to send automatic feedback and alarms to the process and take action if necessary (e.g., re-measure a sample, or start a cleaning cycle). All of these features ensure fully automatic diagnostics of the industrial process – around the clock, seven days a week.