



Application Note AN-RS-037

## 深入了解 785 nm拉曼光

Throughput, spectrograph design, resolution, and MIRA

From its conception, Metrohm Raman has specialized in 785 nm Raman spectroscopy, as there is concrete evidence for the superiority of 785 nm laser excitation compared to other options. Wavelength can ultimately inform the choice of systems for Raman customers – 532 nm for strong signal or 1064 nm for reduced fluorescence. The choice of 785 nm Raman with fluorescence rejection offers users the best of both worlds. Sensitive sampling and short analysis times, small form-factor, and superior identification capabilities are the strongest arguments for choosing to use 785 nm handheld Raman systems. Historically, the strongest

argument against using 785 nm Raman is that approximately 20–30% of materials fluoresce under excitation at this wavelength. Metrohm's patented XTR® method reduces fluorescence interference and permits us to offer the very best of Raman analysis.

This application describes signal-to-noise ratio (SNR) in terms of high throughput, free-space spectrograph design, CCD detector quantum efficiency, and low laser powers for 785 nm systems. High SNR and good spectral resolution ultimately lead to improved library matching for fast and accurate material ID with MIRA XTR DS.

## INTRODUCTION

The resolution of a system is its ability to resolve the natural bandwidth of Raman bands. MIRA (Metrohm Instant Raman Analyzer) systems have a resolution of 8–10  $\text{cm}^{-1}$  with SNR of

approximately 2400. Ultimately, high resolution contributes to improved library correlation for material identification and superior identification of components in a mixture.

## HIGH THROUGHPUT

High throughput, or the delivery of the maximum number of photons to the detector, is the most important factor in obtaining high SNR for any Raman spectrometer. 785 nm systems have an inherent advantage because short wavelengths scatter more Raman photons than longer wavelengths ( $\lambda$ ). The relationship

between signal and excitation wavelength is expressed as  $1/\lambda^4$  and can be used to determine that 3.2x more Raman photons are emitted with 785 nm excitation than 1064 nm. Even so, only one in one million incident photons will be emitted as Raman-scattered light.

## SPECTROGRAPH DESIGN

MIRA spectrometers are built upon a free space design, which is somewhat unique in the world of handheld Raman. Many systems employ fiber optic coupling, which suffers from lower throughput and, typically, higher background noise arising from auto-fluorescence in the fibers themselves and incomplete filtering of incident

light. The type of detector also influences the sensitivity of a system. In 785 nm spectrometers such as MIRA, Charge Coupled Device (CCD) detectors optimize throughput with a quantum efficiency of 75–85% while contributing very little noise. In short, MIRA's design provides the best possible combination of SNR and sensitivity.

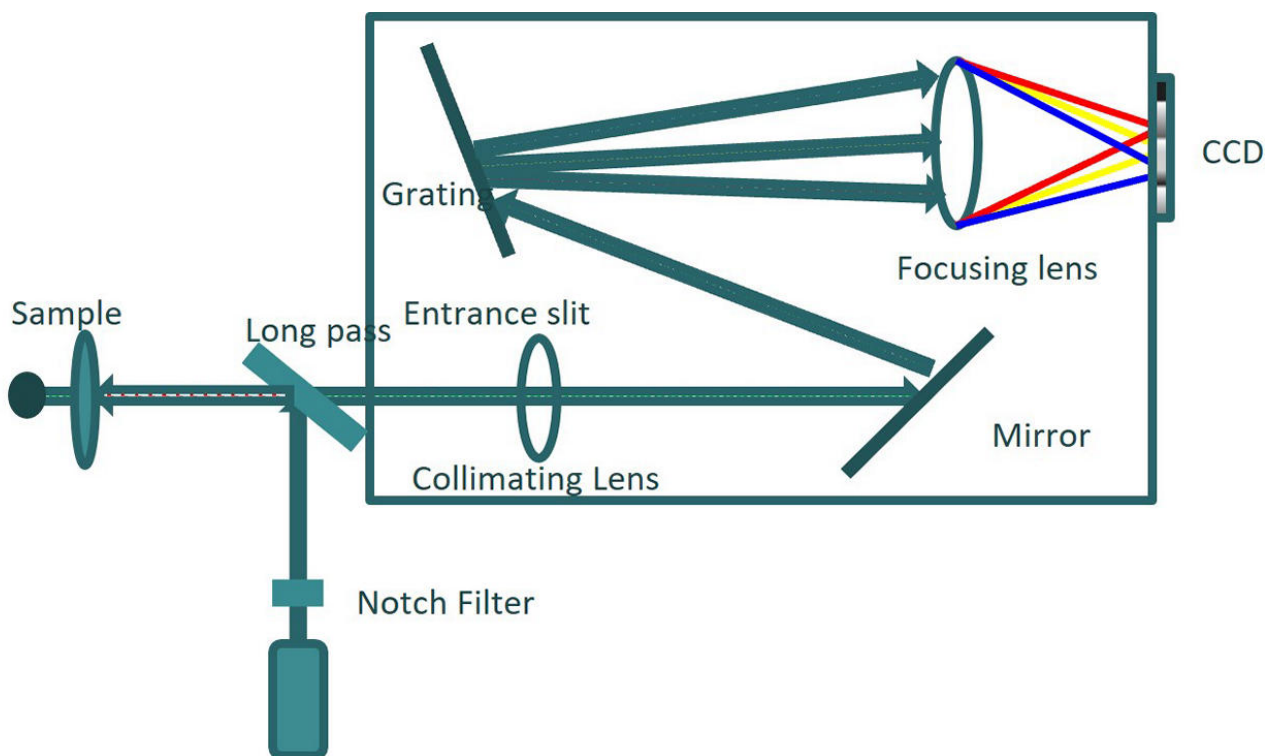

**Figure 1.** Free space Raman spectrometer design.

## LOW LASER POWERS

When a Raman system has high throughput, good quantum efficiency, and very little background noise, a low powered 785 nm laser can be used with very short integration times to collect data with excellent SNR. This means

better sensitivity for optimal library matching. Low laser powers preserve system battery life, which is essential for handheld Raman field applications. Lower laser power also poses less risk of sample degradation for safer analysis.

## SIGNAL-TO-NOISE COMPARISON

A demonstration of how wavelength, laser power, acquisition times, and SNR are related can be found in **Table 1** and **Figure 2**. Observe that 1064 nm Raman requires 440 mW of laser

power (vs. 50 mW for 785 nm systems) and nearly 10 times the sample time to compare with the SNR for 785 nm Raman.

Wavelength	Laser Power	Sample Time	SNR
785 nm	50 mW	0.98 s	487
1064 nm	440 mW	9.30 s	492
1064 nm	380 mW	10.48 s	354
1064 nm	260 mW	15.22 s	277
1064 nm	180 mW	22.72 s	165
1064 nm	100 mW	31.60 s	121
1064 nm	50 mW	40.53 s	71

**Table 1.** Colors in Table 1 correspond to those in Figure 2.

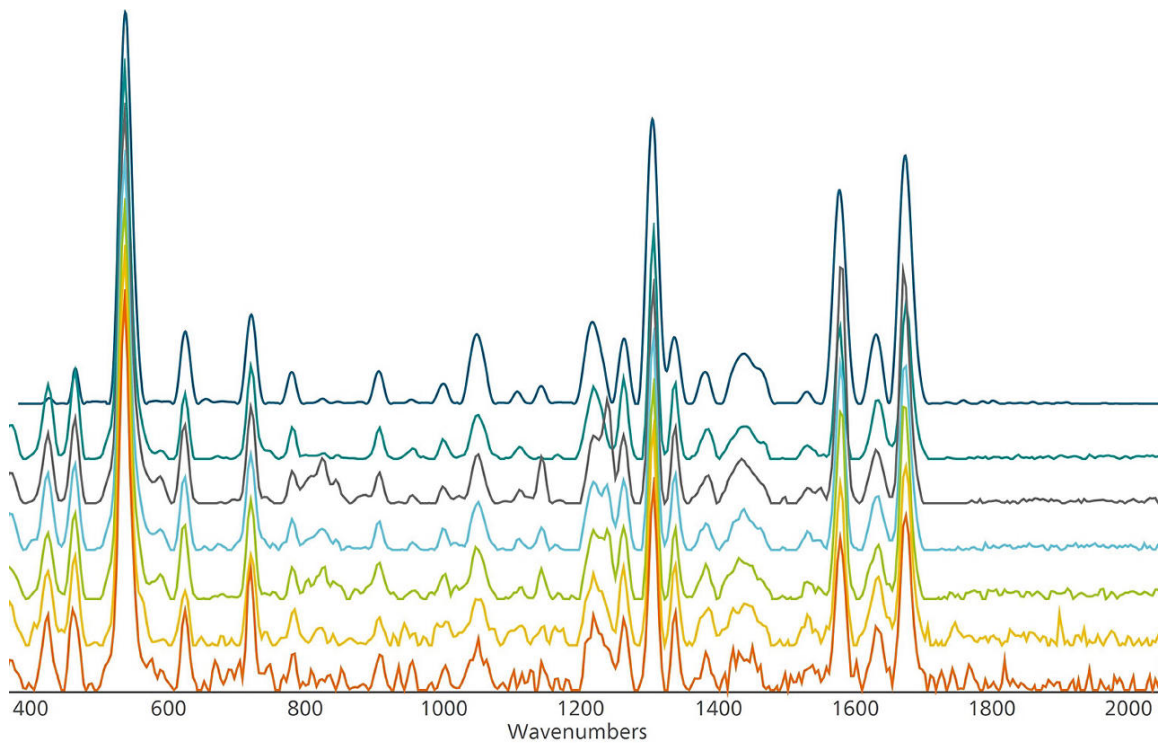

**Figure 2.** Spectral SNR at different wavelengths and laser powers.

## SAMPLING AT 785 NM

To summarize **Table 1** and **Figure 2**, 785 nm Raman collects high resolution data with very short acquisition times and low laser power. This combination reduces risk of laser degradation to the sample. In the worst scenarios, it may prevent the ignition of sensitive or unstable

materials. It also reduces power draw, preserving the life of the battery—a critical asset for long hours in the field. Better accuracy at identifying components in a mixture is another significant advantage.

## LIBRARY MATCHING

Ultimately, high SNR improves library correlation for superior material identification and recognition of components in a mixture. **Figure 3** demonstrates positive identification of both components in a mixture of sugar and citric acid. With 1064 nm Raman, only sugar was identified.

This mixture exhibits significant fluorescence in its Raman spectrum, but XTR routines on our 785 nm system (MIRA XTR DS) achieved sufficient resolution to permit identification of both components and their relative spectral weights.

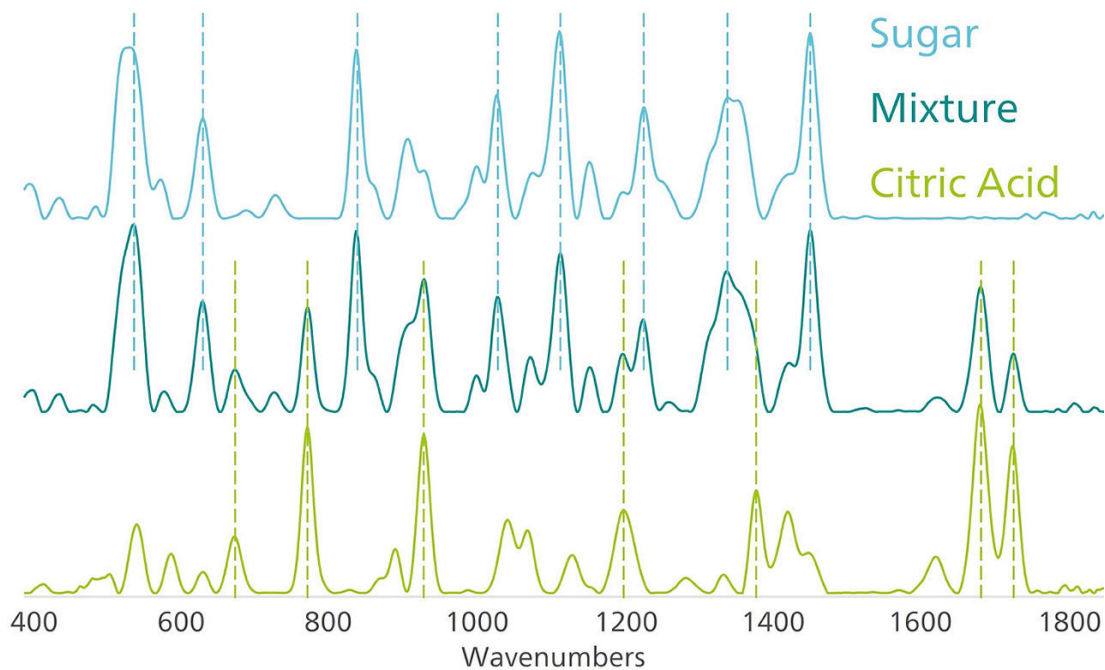

**Figure 3.** Mixture identified by MIRA XTR DS as sugar (56% spectral weight) and citric acid (32%).

## CONCLUSION

785 nm handheld Raman is inherently a unique form of spectroscopy. Very few analytical techniques can compare with its ability to provide instant, on-site materials identification.

Metrohm Raman takes 785 nm sampling to the next level with sensitivity, robustness, convenience, and accuracy.

## CONTACT

Metrohm AG  
Ionenstrasse  
9100 Herisau

[info@metrohm.com](mailto:info@metrohm.com)